

WooKong **HELI**

User Manual

V 1.8



www.dji-innovations.com

Disclaimer





DJI Innovations assumes no liability for damage(s) or injured incurred directly or indirectly from the use of this product.

DJI WooKong is registered trademark of DJI Innovations. Names of product, brand, etc., appearing in this manual are trademarks or registered trademarks of their respective owner companies. This product and manual are copyrighted by DJI Innovations with all rights reserved. No part of this product or manual shall be reproduced in any form without the prior written consent or authorization of DJI Innovations. No patent liability is assumed with respect to the use of the product or information contained herein.

Reader's Guide for This Manual

Please strictly follow these steps to mount and connect WooKong for Heli (WKH) system on your helicopter, as well as to install the WKH Assistant Software on your computer. Please pay attention at **Lite** for the difference between WKH and WKH Lite.

Icons seen in this document:

	FORBIDDEN		Please refer to the page(s) mentioned		R/C Transmitter configuration required		WKH Assistant configuration required
	CAUTION		Assembly & Mounting Tips		General Tips		Correct/ Wrong

Contents

DJI WKH Introduction	3	<i>B8</i>	R/C Transmitter Calibration	17
Package Contents	4	<i>B9</i>	System Check	18
Mounting and Connection	5	<i>B10</i>	Autopilot	19
<i>A1</i> Before you Begin	5	Flight	20	
<i>A2</i> Mount the devices on your helicopter	5	<i>C1</i> Digital Compass Calibration	20	
<i>A3</i> Connections.....	7	<i>C2</i> MANUAL MODE Test Flight	21	
<i>A4</i> WKH Assistant Software Basic Operation	9	<i>C3</i> Fail-Safe	22	
Flight & Configuration Procedure Brief	10	<i>C4</i> Autopilot Test Fight.....	23	
Configuration Procedure	11	Maintains	23	
<i>B1</i> GPS & IMU Mounting	11	Firmware Upgrade	25	
<i>B2</i> Control Mode Switch	12	Product Info.....	25	
<i>B3</i> Flybarless	13	Appendix	26	
<i>B4</i> Swashplate.....	14	WKH LED Indicator Description	26	
<i>B5</i> Pitch and Throttle Curve Setup.....	14	WKH Lite LED Indicator Description	26	
<i>B6</i> Tail Gyro.....	15	Product Specifications.....	27	
<i>B7</i> Engine Governor	16			

DJI WKH Introduction

WKH is the flight system designed for serious scale helicopter enthusiasts providing GPS for self-leveling, position hold, speed control and built-in tail gyro which completely takes the stress out of flying RC helicopters for both professional and hobby applications. WKH can be installed in a variety of models, from small electric helicopters to large gasoline and turbine helicopters. WKH Lite is the no GPS and LED version of WKH.

Multiple control mode based on autopilot system:

Lite There is no *GPS Atti. Mode* in WKH Lite.

	<i>GPS Atti. Mode</i>	<i>Atti. Mode</i>	<i>Manual Mode</i>
Command Stick Meaning	Helicopter attitude control; Stick center position for 0° attitude, its endpoint for 45° which is a fixed limit.		Mechanical driving directly
Command Linearity	YES		NO
Stick Released	Lock helicopter position when GPS signal is adequate	Only altitude stabilizing	Recommend for experience pilot
Altitude lock	Best maintain altitude above 3 meters		NO
Flight Altitude	No limit, but will switch into <i>Atti. Mode</i> automatically over 50m.	No limit	No limit
Stabilization	Flybarless stabilizing on ELEV and AILE direction is available for all control mode		
GPS Lost	After 10s when GPS signal lost, system enters <i>Atti. Mode</i> . Automatically.	Only performing attitude stabilizing without position lock.	---
Safety	Attitude & speed mixture control ensures stability.		Depends on experience
	Fail-safe featured, auto hover or level if transmitter signal lost		
Appropriate Applications	High agility for all flying		---

Built-in functions include:

- Integrated tail gyro

The flying direction (YAW) of helicopter will be effected by cross wind. WKH can detect the drifting angle & Speed, and control the rudder servo to eliminate such influences.

In the case of flying forward in cross-wind, Tail Gyro can work on two different modes as the example shown.

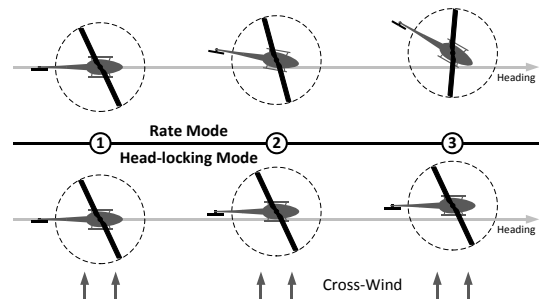

- Flybarless rotor head support
- Integrated engine governor for internal combustion engines
- Build-in semi auto take off & landing

Package Contents

Main Controller

The Main Controller (MC) is the brain of the WKH. MC communicates with the IMU, GPS/Compass, engine governor, servos and RC transmitter to carry out autopilot functionality. USB interface is for WKH configure and firmware update from a PC.

(System requirement: Windows XP SP3 or Windows 7)

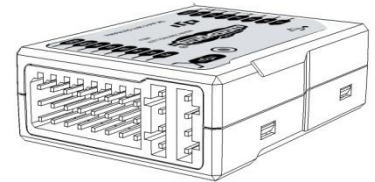

x1

GPS & Compass module

Lite Not in WKH Lite

The GPS/Compass module should be installed on the tail boom, where there is a clear view of the sky.



x1

IMU

The Inertial Measurement Unit (IMU) consists of one 3-axis accelerometer, one 3-axis gyroscope and a barometer.

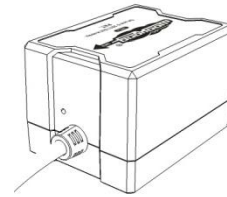

x1

GPS Tail Boom Mount

Lite Not in WKH Lite

The GPS Tail Boom Mount and double-sided foam tape enable secured installation for the GPS/Compass module on almost any helicopters.

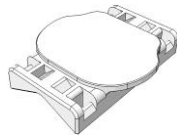

x1

3-PIN Servo Cable

Cables used to connect the Main Controller to the RC receiver.



x10

LED Indicator

The LED indicates the different system states.

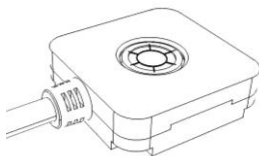

x1

Micro USB Cable

This cable is used to configure WKH, update firmware.

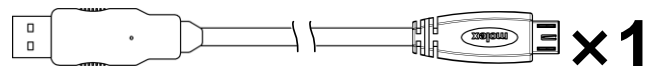

x1

3M 5925 Double Sided Tape

Lite Not in WKH Lite

Only for GPS & Compass module



x4

Warranty Information Card

WKH comes with a two-year warranty, as described on this card. Please keep this for your personal records.

Mounting and Connection

A1 Before you Begin

Fly the helicopter without WKH in open area or large field and make sure that the helicopter works properly without any autopilot assistance. To do so, you will need external tail gyro. This is a good time to isolate and resolve unwanted vibrations. IT IS IMPORTANT THAT YOU SHOULD NOT SKIP THIS STEP.

A2 Mount the devices on your helicopter

IMU

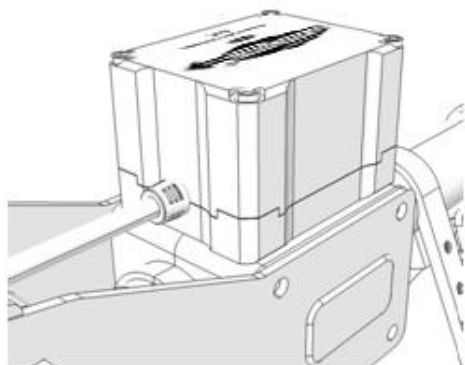

- **Where?** The IMU is best positioned near the helicopter's center of gravity, where vibration is relatively low.
- **What orientation?** Orient the IMU such that the arrow marked on the above surface of the IMU faces the sky and points directly forward, backward, left or right. The sides of the IMU should be precisely parallel to the helicopter body.
DO NOT MOUNT THE IMU UPSIDE-DOWN.
- **How?** Use double-sided foam tape for secured installation.



- 1 Check the double-sided foam tape or Velcro regularly to ensure that the IMU is securely positioned.
- 2 DO NOT cover the ventilation holes, keep them unobstructed.
- 3 The IMU module is NOT water-proof or oil-proof.

GPS & Compass Module

Lite WKH Lite customers can skip this step.

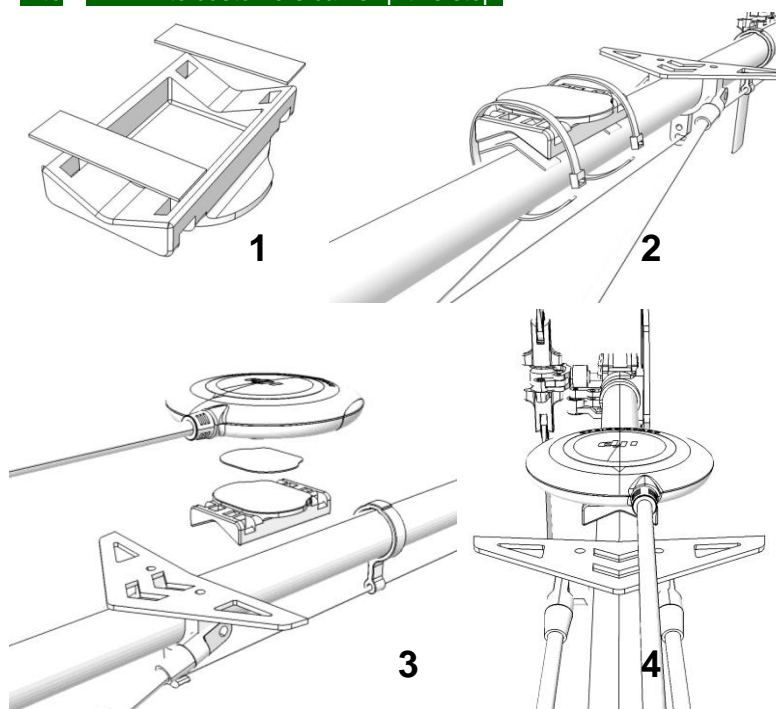

- **Where?** Mount it on the tail boom, between the rotor-head and the tail-rotor. The compass is sensitive to magnetic interference, so position the module at least 20 cm from servos and 30 cm from electric motors or gasoline (petrol) engines. The GPS is sensitive to vibration interference, so position the module at least 10 cm from the tail rotor. The GPS should not be close to the main rotor head because rotor blades can interfere with GPS satellite signal, the farther from the center of the rotor disk, the better. For scale helicopters we find either behind or in front of main shaft GPS positions can be applied. It can also be installed inside the fuselage where the fiber glass shell is relatively thin.
- **What Orientation?** The DJI logo marked on the GPS should face the sky, with the orientation arrow pointing directly forward. The GPS/Compass is packaged with a special indication line for mounting for the first time.



- 1 If you are uncertain whether materials near the GPS/Compass module are magnetic or not, you can use a compass or magnet to check it.
- 2 GPS/Compass mounting-support hardware is included in the package. If however you prefer to use your own GPS/Compass mount, please make sure that the mount material is NOT magnetic.

Main Controller

- **Where?** There is no orientation requirement for the Main Controller. Maintain at least a 20-centimeter-distance between the Main Controller and the engine or motor. Choose a mounting location where as shorter servo extension wires are needed as possible. This helps reduce the risks of electronic interference. Please also make sure the USB port is accessible when installing the Main Controller so as to facilitate software configuration.

 After choosing a location to mount the Main Controller, it is recommended that you **DO NOT** mount the Main Controller until all wirings and software configurations are completed.

LED Indicator

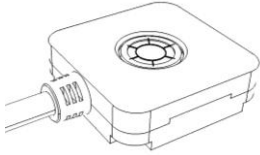

- **Where?** Place the LED indicator at appropriate location of helicopter body.



Make sure the LED indicator face down, and you can see the light.

A3 Connections

GPS/COMPASS: Mount to the Tail boom, 20 cm from servos, 30 cm from motor, 10 cm from tail rotor.

WKH Lite has no GPS/Compass

In-line CAN-Bus Port: This CAN-Bus port can be used for the LED module connection or for future hardware upgrades.

LED: The LED indicates different states of whole system. WKH Lite user should connect LED to CAN-Bus port on the MC directly.

Internal vibration isolation design, enable a more convenient IMU mounting.

Micro-USB: PC connection for configuration and firmware upgrades.

Battery
MUST supply 4.8 - 8.4 volts. Could be connect to any of the spare I/O port.

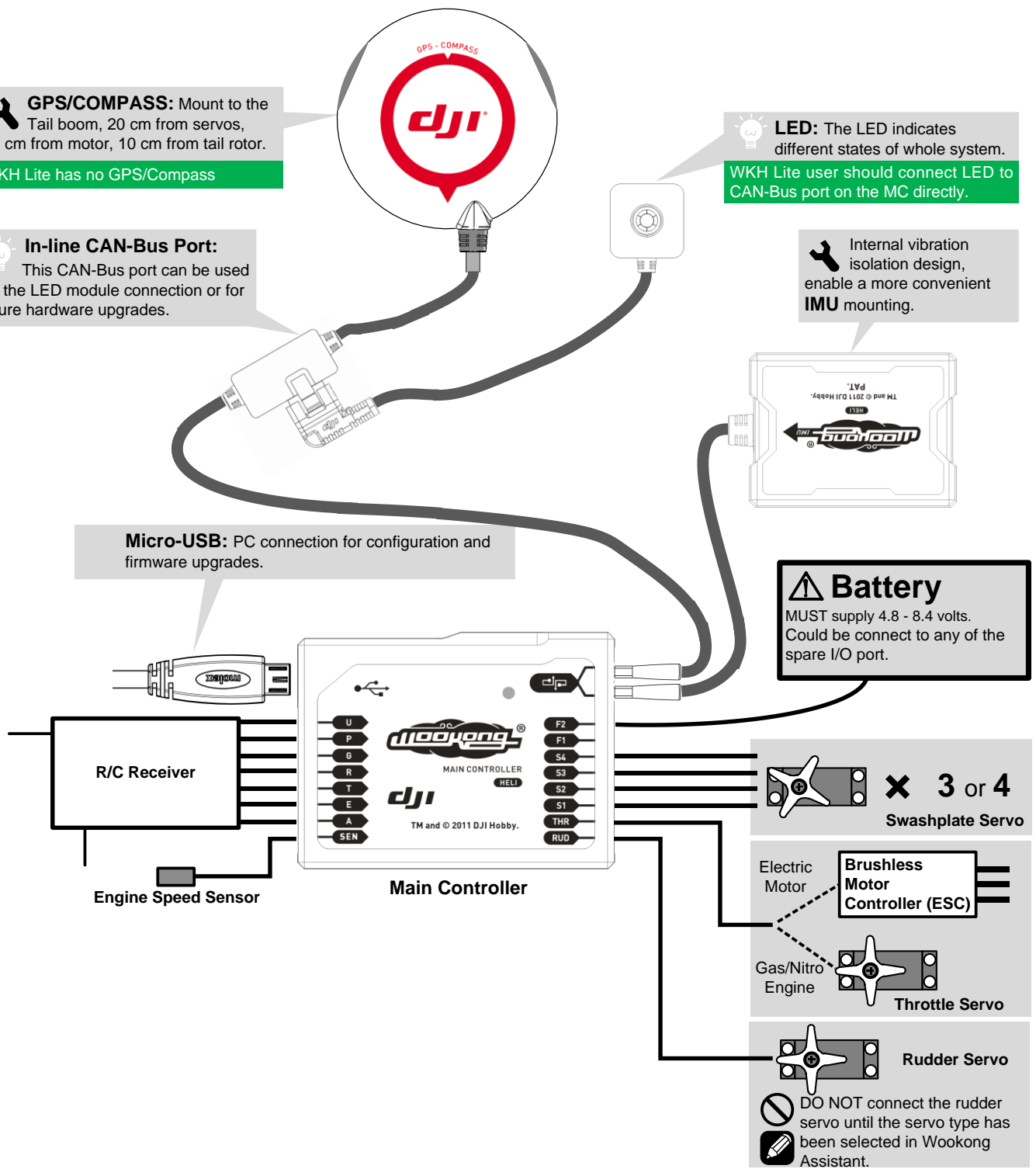

CAN Bus-Interface for WKH Module

WKH Main Controller uses CAN-Bus to power and communicate with other WKH modules. Three connection ports are provided: two on the Main Controller and one in-line connection on the GPS/Compass wire. WKH identifies the connected devices automatically without configuration.

- GPS/Compass module can be connected to either port of Main Controller.
- IMU can be connected to the Main Controller.

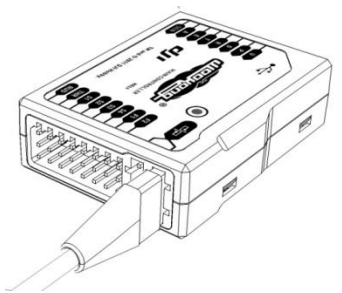

Receiver & Servos

STEP1: Set the transmitter to single-servo CCPM (Futaba: H-1; JR/Spectrum: 1sNORM; Hitec: 1-Servo 90°).

Connect the receiver to the Main Controller input servo ports.

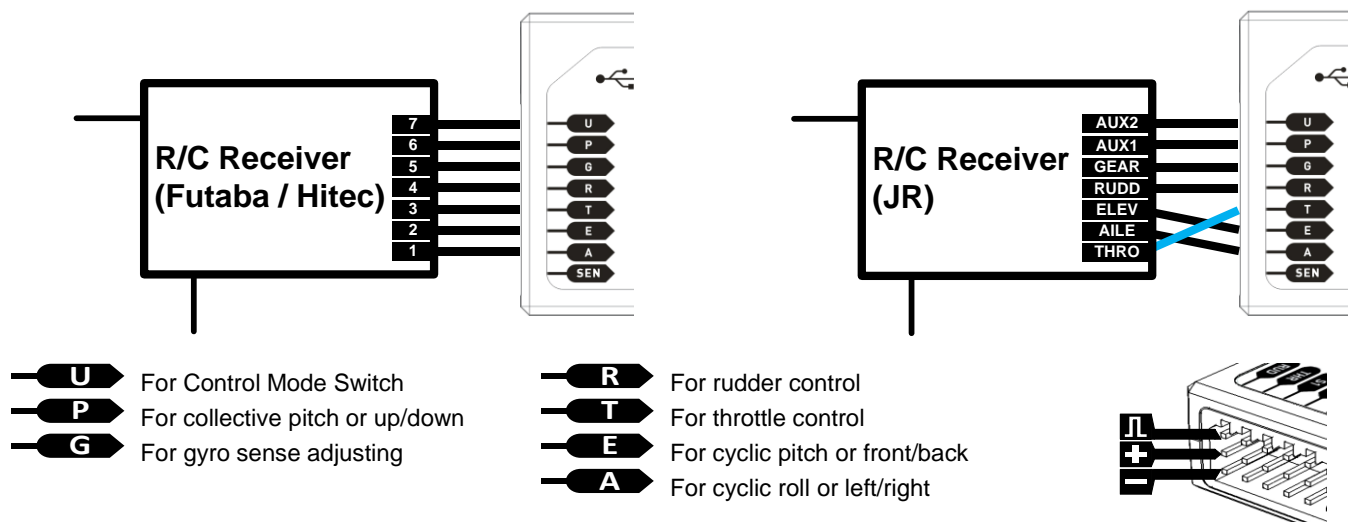

STEP2: Connect the cyclic servos and throttle servo or ESC (**NOT** the rudder servo) to the WKH output servo ports using the diagram corresponding to the swash type of your helicopter.

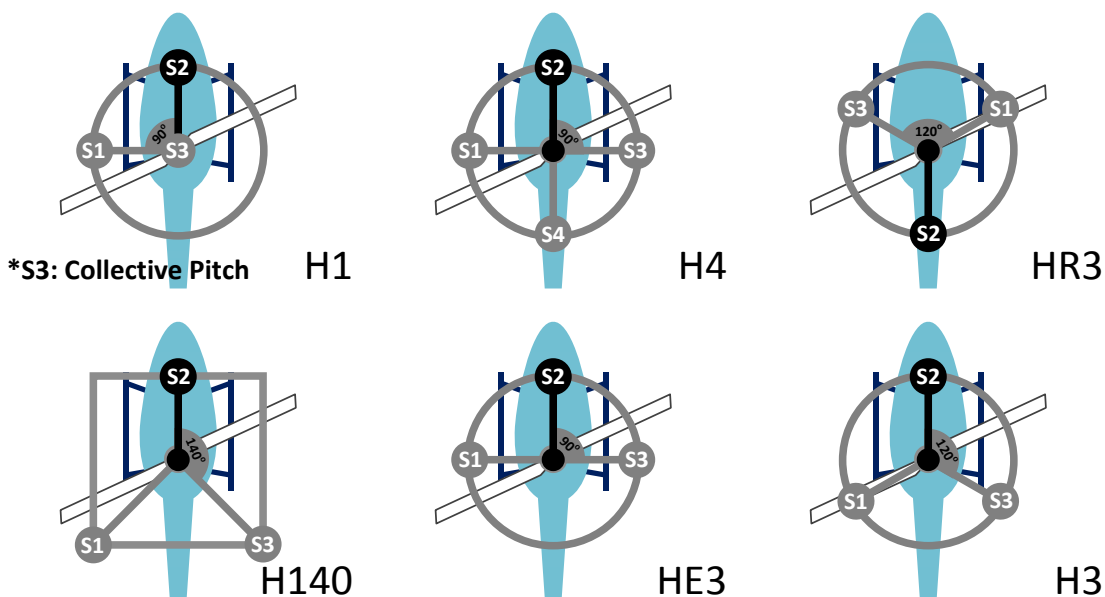
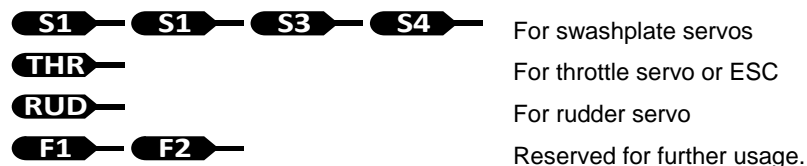

Battery or BEC

WKH uses the same power source as the servos and receiver; power to all electronics connected to the Main Controller can be supplied by either servo input or output ports on the Main Controller. WKH operates with a power source between 4.8 to 8.4 volts DC. When choosing a power source, bear in mind that all servos and WKH will use that same power source, thus please make sure the power source you use will also satisfy the servo requirements. A high capacity battery of 2000mAh or above is strongly advised, especially for large scale electric powered helicopter. Depending on servo types, digital servos will require 10A BEC for multi-bladed applications.



The power consumption of WKH is 5W maximum (testing condition: 0.9A @ 5V). For some small scale helicopters, the BEC provided may not be able to supply enough overall power consumption, please use high performance BEC.

A4 WKH Assistant Software Basic Operation

Software and Driver Installation

Please read Software & Driver Installation Guide, the micro-USB port is used for WKH configuration and update firmware.

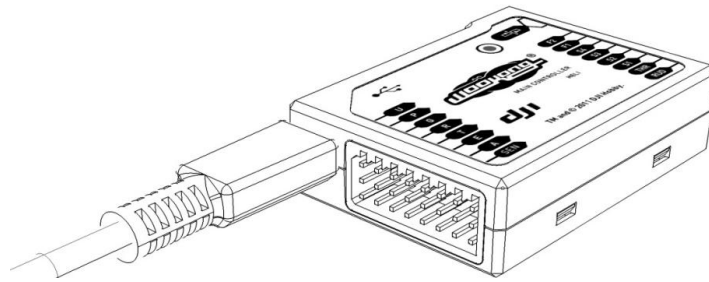

Introduction for Software GUI

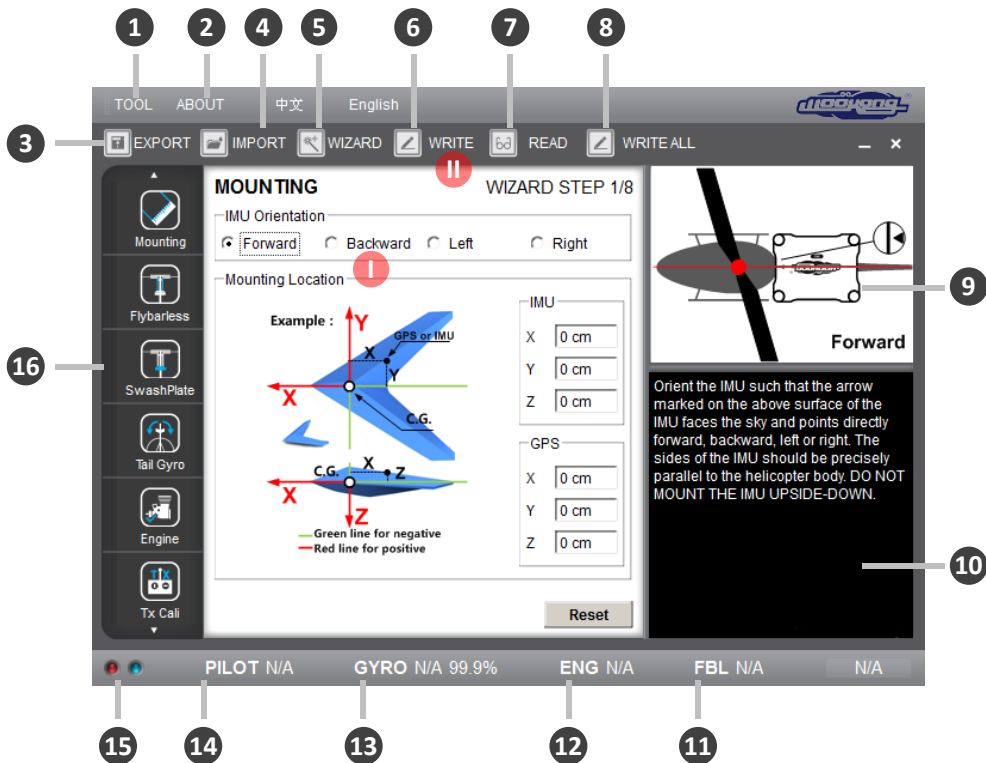

How to adjust parameters?

- I** Red and bold text indication if you changed anything;
- II** Write parameters to main controller.
- 10** Except the direct edit items, they can be written to main controller directly.

1 TOOL

- ➔ **Firmware upgrade:** update your firmware from DJI server, keep your WKH system up-to-date.
- ➔ **Sign In:** In order to provide better service to you, please register for firmware update, software and manual download. If you have registered, please sign in here.

2 ABOUT

- ➔ Information regarding your WKH

3 Export: export/save WKH configurations in files.

4 Import: load previously saved configurations.

5 Wizard: step-by-step, for your first-time-configuration.

6 Write: write data of latest settings of the current page to your WKH main controller. The parameter value or the title of which will appear as red and bold in font when modifications have been made, make sure you click the

“Write” button to update your system.

7 Read: read parameters from main controller.

8 Write all: write latest settings and changes of all files to your main controller.

9 Graphic guidance

10 Text guidance

11 Flybarless function ON/OFF indication

12 Engine governor working mode indication

13 Tail gyro working mode & gyro sense indication

14 Autopilot working mode indication

15 Red light: WKH←→ PC has been disconnected.

Green light: WKH←→ PC has been connected.





















Blue light: WKH←→ PC communication.

16 Here you can find all the configuration pages the same as in the “Wizard”.

Flight & Configuration Procedure Brief



- 1 For safety reasons, during configuration and system setup, please disconnect the power supply for Electric motor.
- 2 Please do the following configurations in **Manual Mode** of the autopilot system.

Steps	Description	Page
 B1 GPS&IMU Mounting	Please measure the center-of-gravity (C.G.) of your helicopter, and fill in the distance between IMU/GPS and C.G. of helicopter in X, Y & Z axes;	11
 B2 Control Mode Switch	Adjust your transmitter for channel  , and then you can switch the autopilot working mode between Manual / GPS Atti. / Atti. ;	12
 B3 Flybarless	Please select flybarless ON/OFF. You might need to adjust parameters during test flight;	13
 B4 Swashplate	Setup you swash plates according to your helicopter specification;	13
B5 Pitch & Throttle Curve Setup	Set pitch & throttle curve on your transmitter according to our suggestion;	14
 B6 Tail Gyro	Make rudder correctly responding to your transmitter commands (rotating C.W. or rotating C.C.W.);	15
 B7 Engine Governor	Both electric motor and gasoline engine require setting;	16
 B8 R/C Transmitter Calibration	 ,  ,  &  are required to do;	17
 B9 SYSTEM CHECK 	Check controller output, IMU mounting and battery performance;	18
C1 Digital Compass Calibration	Slide the control mode switch on transmitter 10 times, and WKH will enter the compass calibration mode;	20
 C2 Manual Mode Test Flight	Please strictly follow the procedure during flight test, you may need to adjust the following parameters to achieve the best flight performance:	21
 B3 Flybarless control parameters if you've enabled Flybarless;		13
 B6 Tail Gyro sense;		15
B7 Engine speed and Gov Gain for Gasoline / Nitro engine.		16
 C3 Fail-Safe 	Please strictly follow the failed-safe setting procedure; otherwise this function might not be working correctly.	22
 C4 Autopilot Test Flight	Please strictly follow the procedure during flight test, you may need to adjust the following parameters to achieve the best flight performance:	23
 B10 Autopilot control parameters;		19
B3 Flybarless control parameters if you've enabled Flybarless;		13

Lite Assistant software of WKH and WKH Lite are different. However WKH Lite assistant software will become WKH assistant software automatically with a GPS module plugged into MC when you open the assistant software.

Configuration Procedure

B1 GPS & IMU Mounting

Lite WKH Lite customers can skip GPS mounting.



Assistant Software - MOUNTING page

MOUNTING

WIZARD STEP 1/8

STEP1

IMU Orientation

- Forward
 Backward
 Left
 Right

Mounting Location

STEP2

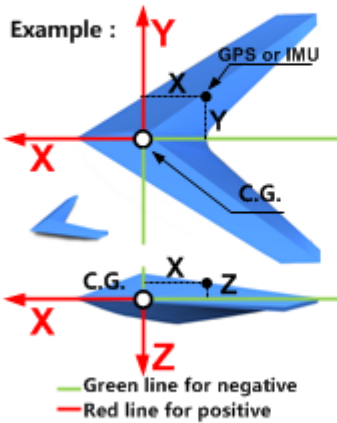

IMU

X

Y

Z

GPS

X

Y

Z

Not showed in WKH Lite

STEP1: Select IMU Mounting orientation

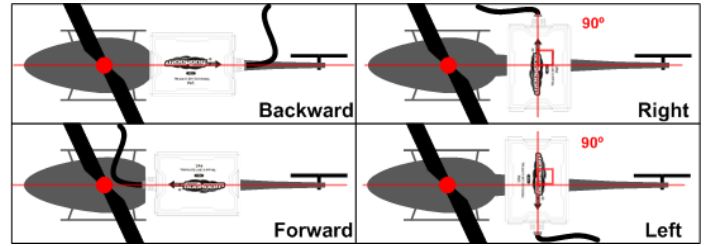

STEP2: Fill in the distance between IMU/GPS and the C.G. of helicopter in X, Y & Z axes, please measure the C.G. with following method:

- a) Adjust your helicopter, and make it balance on X and Y axle as shown below.

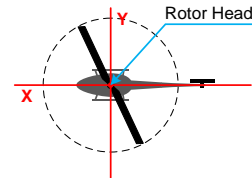

Balance on X Y

- b) The C.G. should be on the extended line of helicopter main shaft.

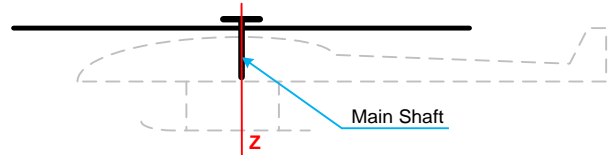

- c) Hang the helicopter by the tail and use a plum line to find C.G. on Z axle. You can use your own methods to estimate the C.G. of your helicopter.

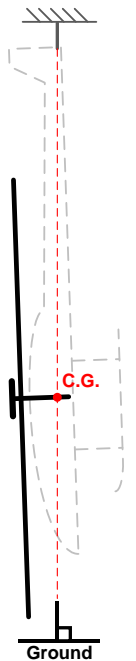

*Step c) is not required to pod/boom, and scale helicopter. Simply enter value zero will be sufficient.

GPS normally mounted on tail boom, thus X and Z could be zero, distance between GPS to main shaft is X.

Note: measurement in CM



- 1 You must re-configure if the ALL-UP-WEIGHT had been changed on your helicopter,
- 2 If mounting locations are not accurate enough or the sign were wrong, error on Y , Z axle will leads helicopter vibrating, error on X axle will leads drifting during spinning.

B2 Control Mode Switch

Lite WKH Lite customers have no **GPS Atti. Mode**.

- 1 The transmitter you used must be Fail-Safe featured, which allows you to setup fixed outputs for all channels if the receiver loses signals, otherwise WKH will not enable the Fail-Safe.
- 2 Working mode for your transmitter should be HELICOPTER.
- 3 All the channels in your transmitter should be working independently: NO CCPM, NO channel MIX , NO EXP.
- 4 You need at least one 2 or 3-position switch on your transmitter to be set as the control mode switch.



In Assistant Software, page TX-MONITOR:

TX MONITOR
Control Mode Switch

MANUAL
Fail-Safe
Atti.
Fail-Safe
GPS Atti.

WIZARD STEP 2,7/8
Sticks Monitor
T
G

Command Sticks Calibration
P
R
E
A

Calibration START

It will turn into Atti. in WKH Lite.

Once the switch position has been matched to specific control mode, you will see the high-light as shown following.

TX MONITOR
Control Mode Switch

MANUAL
Fail-Safe
Atti.
Fail-Safe
GPS Atti.

WIZARD STEP 2,7/8
Sticks Monitor
T
G

Command Sticks Calibration
P
R
E
A

Calibration START



Whichever 2 or 3 positions switch/channel user has

selected or decided to use in the transmitter (for control mode switching), in this case channel U marking on main controller. Use sub-trim or end-point (+/-) fine tuning on your transmitter, move the slider of channel U to the specific range until Assistant Software indicates that it is in **Manual, GPS Atti., Atti. and Failed-Safe mode**.

Notice: To move the slider is to adjust sub-trim or end-points of the channel selected.



For 3-positions switch, you should assign:

Position-2 to Atti. Mode;

Position-1 to Manual Mode;

Position-3 to GPS Atti. Mode;

Or reverse the assignment for **Position-1** and **Position-3**.

For 2-positions switch, you should assign:

Position-1 to Manual Mode;

Position-3 to GPS Atti. Mode;

Or reverse the assignment for **Position-1** and **Position-3**.

Notice: Please see page 3 for introduction of autopilot control modes.



Set Fail-Safe output of receiver to input port-U, move the slider to the range which reads **Fail-Safe MODE.**

IMPORTANT: WKH would not execute Fail-Safe protection if you don't set it properly. You can verify the Fail-Safe settings by shutting down your transmitter, and then you can use the following method to check whether WKH was already in Fail-Safe mode.



You can check the current control mode of WKH using either of the following methods:

- Check the Assistant status bar at the bottom side of the software interface.
- Check the LED indicators status on GPS/Compass module, see Appendix in this manual for details.

B3 Flybarless



When system is powered on, you must not move your helicopter or sticks on transmitter until the system initialization is finished (about 5 second).



Once you changed the Flybarless to "ON", the AILE and ELEV swash mix ratios in swashplate settings will be disabled, while **[Direction Reverse]** button will always be available for AILE and ELEV. After you have set the Flybarless to "ON", you have to adjust your swashplate parameters before setting your Flybarless control parameters.



- 1 You have to adjust flybarless function and test it in **Manual Mode** first.
- 2 Don't try to use **Atti. Mode** and **GPS Atti. Mode** until you can fly flybarless without any problems.
- 3 You might need to reduce the control gain of flybarless if you cannot make the helicopter stably hover or fly under **Atti. Mode**, and **GPS Atti. Mode**.



Assistant Software, page-FLYBARLESS:

FLYBARLESS WIZARD STEP 4/8

STEP1

Flybarless

ON OFF

STEP2

Parameter

	AILE	ELEV
Gain	0%	0%
Direct Input	0%	0%
Cyclic Rate	0 deg/s	0 deg/s
Flybar Weight	0%	0%

STEP1: Choose flybarless ON/OFF, you MUST NOT enable flybarless function for helicopter with flybar, otherwise the helicopter will be out of control.

When Flybarless is turned on, elevator & aileron will have stabilization in manual mode.

STEP2: During test flight procedure, please perform the following configuration procedure.

Gain *Parameter range: 20% to 500%*

If the helicopter is sluggish, increase it; if the helicopter oscillate back after brake, decrease it. Adjust this parameter 10% increment time until your control feeling is sharp and the helicopter would not bounce after braking.

Note: this parameter will only affect the stability but not control feeling.

Direct Input *Parameter range: 30% to 300%*

This is the direct connect ratio for command stick effect, the rolling speed might not be uniform if it is too high, and also will lead to quick or sudden change in cyclic response.

Cyclic Rate *Parameter range: 20 deg/s to 450deg/s*

This is the helicopter body rolling speed ratio, which determines the maximum rolling speed corresponding to command stick end point. The helicopter would response very quickly if it is too high, for example high rate in 3D.

Flybar Weight *Parameter range: 20% to 300%*

The higher the value, the better the static stability of the helicopter. But, it will increases the sluggish on your control feeling, such as bank turn, and braking is also not sharp enough, like an large inertia helicopter. Similar to adding weight to blade tip.

Suggested Parameters

	ALIGN-600 Nitro (Default)		ALIGN-600Electric		LOGO 700		Maxi Joker 3DD	
	AILE	ELEV	AILE	ELEV	AILE	ELEV	AILE	ELEV
Gain	100	100	70	90	150	160	200	250
Direct Input	100	100	120	120	160	180	240	280
Cyclic Rate	180	180	150	150	150	150	130	130
Flybar Weight	100	100	80	80	130	130	150	150

B4 Swashplate



You should finish the setup for your swashplate in **Manual Mode**.



In Assistant Software, page-SWASHPLATE:

 If you have enabled Flybarless function, then Swash Mix ratio settings for AILE (Cyclic Roll) and ELEV (Cyclic Pitch) will not be available, please read Flybarless setting for detail.

 Please read your helicopter's manual, and make sure the swashplate servo linkage and all the mechanical parts were correctly adjusted before you use the above function for swashplate level adjusting.

Swash Mix is identical to Tx CCPM mixing, this function is no longer available on Tx after set to single servo (on Tx).





STEP1: You have to set the transmitter to



single servo swash

(Futaba:H-1;JR/Spektrum:1sNORM;Hitec: 1-Servo 90°), and WKH will do the CCPM instead.

STEP2: Please make your selection according to your **swashplate type**. **IMPORTANT**

STEP3: The swashplate can be rotated in 360°, with 1°step increase or decrease. Not required in most conditions.

STEP4: Click  /  button, you can reverse the working **Direction** of swashplate servos. Servo **Trim** is in range -100 to +100, with default value at 0. The swashplate must be level. The **Current Output** will indicate whether your swashplate servos are on their center position or not.

STEP5: Click  /  button, you can reverse the moving direction for PITCH (Collective Pitch), AILE (Cyclic Roll) and ELEV (Cyclic Pitch).

The **Swash Mix ratio** is 0~100%, which defines the maximum working range for PITCH (Collective Pitch), AILE (Cyclic Roll) and ELEV (Cyclic Pitch), similar to Tx setting.

Suggestion: 35~45%, it can give you soft flying movement, and easy to configure for the following parameters.

B5 Pitch and Throttle Curve Setup

We suggest you to use the following pitch curve for better lifting power and safety descending speed.

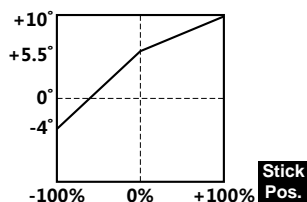

Throttle curve for electric power, this is the example for JIVE ESC:

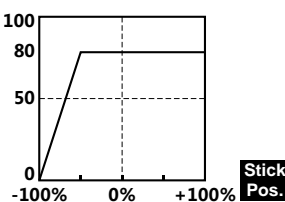

Throttle curve for integrated engine (with governor function):

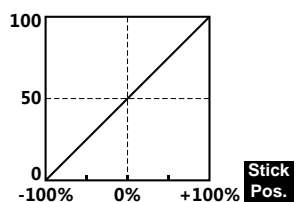

B6 Tail Gyro



When system is powered on, you must not move your helicopter or sticks on transmitter until the system initialization is finished (about 5 second).



Assistant Software, page-Tail Gyro:

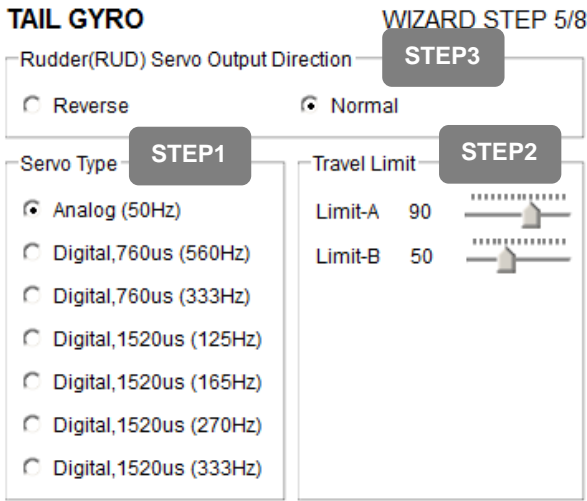

Transmitter related channels

Input	Operation	Description
R	Stick	Rudder command
G	Switch	1. Gyro working mode selection: Rate Mode/Head-Locking Mode 2. Gyro sensitivity setting 3. Quickly slide it from rate mode to head-locking mode for 3 times, the command stick center position would be reset.

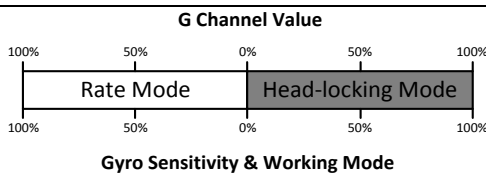

You must also finish the SYSTEM CHECK procedure in later steps, before you fly your helicopter. You might find the Controller Output Check for tail rudder result in opposite rudder moving directions, click **[Reverse]** button to make corrections. Please see [Page 错误未定义书签](#).

STEP1: Please properly set your rudder servo type before you connect your tail-gyro servo to it, otherwise your servo might be damaged due to incorrect servo type chosen.

Analog Servo(1520us @ Receiver Speed)

Digital Servo(1520us165, 270, 333Hz),

Suggested servo type: **JRDS8925HV ; Futaba S9254**

Digital Servo(Digital-760us333,560Hz),

Suggested servo type: **Futaba BLS251 / BLS351**.

STEP2: We have **[Limit A]** and **[Limit B]**(Range:-140 to +140), which represent end-points of the tail rotor pitch. The initial value for both is 50. Adjust these two limit value, make sure your rudder servo can work the full range for your tail rotor pitch, without any mechanical binding. Otherwise, the performance of the tail-gyro will be affected. You can identify which side of the tail rotor pitch is represented by Limit A / Limit B like this:

1. Set one of them to 0, another to 50.
2. Move your rudder stick on your transmitter.
3. One side of the tail rotor pitch will not move.
4. This side should be related to the Limit A / Limit B whichever you are giving value 0 to.

STEP3: Move your rudder stick, and check whether the tail rotor pitch is working to your expected direction. If not, please change to proper direction.

STEP4: Switch your Tail-Gyro working mode to **[Rate Mode]**, take-off your helicopter and hover. If your helicopter drifts on YAW direction obviously, then adjust your tail servo linkage until the helicopter stops drifting. Or you can use trim to fine-tune the rudder servo.



If you used trim during the Tail-Gyro working in Rate Mode, please power off the WKH and re-start it before you wish to use Head-Locking Mode.

STEP5: Gyro Sense setting: Set your gyro sense via transmitter, with the channel which you plug into input port-G on WKH main controller. We suggest you start from 45% in **[Head-locking mode]**, take off the helicopter, reduce the Gyro sense if tail got vibrating; if the tail response too slow and drift then increase it. Land you helicopter and switch to **[Rate mode]**, then take off the helicopter again, fine-tune the rudder servo to make the tail stop drifting and land again. Switch the tail gyro between **[rate mode]** and **[Head-locking Mode]** by 3 times, then center position of Tx will be recorded, now you finished the gyro sense setting. You can identify the Tail-Gyro working mode on the status bar of Assistant Software, but that gyro sense percentage may not be the same as your Tx reading due to different Tx manufacture.

B7 Engine Governor



In Assistant Software, page-ENGINE:

ENGINE WIZARD STEP 6/8

Working Mode **STEP2**

Tx Control For Electric Motor

Governor control For Gas/Nitro Engine

Throttle Servo Working Range **STEP3**

TEST TEST TEST

SET-MAX SET-IDEL SET-STOP **STEP4**

Magnetic Speed Sens **STEP5** Gov Gain **STEP7**

0%

50%

Rotor/Engine Speed **STEP6**

Rotor RPM 800 **X** Gear Ratio 10.0 = Engine RPM 6000

STEP1: Before using **Governor Control** mode, fine tune your Gas/Nitro engine to good condition. Otherwise the performance would be negatively impacted.

STEP2: Select the operation mode:

- Select **[TX Control]** for electric motor;
- For Gas/Nitro engine, select **[TX Control]** first, and finish next step: set throttle servo working range. Then select **[Governor Control]**.

STEP3: SET throttle servo travel range, move the throttle stick to

For Electric	For Gas/Nitro	Click to set
Maximum open position		[SET-MAX]
lowest stick throttle	Engine idling position	[SET-IDLE]
Throttle hold	Cut position	[SET-STOP]

Notice: you must not turn on the throttle-cut.

STEP4: After three of the throttle positions being set, click **[TEST]** button above to review your throttle working range settings. Throttle servo will be forced to stay on each respective position for about 2 seconds. Repeat the **[SET]** procedure if it is not set incorrectly.



If a mistake is made, e.g. **STOP** position being set between **MAX** and **IDEL**, you will be notified by **X** (Wrong), and Engine governor will be forced to work in **[Tx Control]** mode automatically.

STEP5: A third party engine speed sensor is required for the engine speed governor to function. We suggest using Futaba magnetic engine speed sensor. You have to adjust the sensor/magnet mounting, and leave a proper space between the sensor head and magnet. You can check this with the percentage bar at page "ENGINE", over 60% means the magnet is directly facing the sensor, and less than 2% means that the sensor is far from directly pointing at the magnet.

Notice: Only **ONE** magnet can be mounted on cooling fans of the engine.

STEP6: Please refer to user manual of your helicopter and engine, find the following parameters:

- Main rotor speed, in range: 800 to 2500 RPM;
- main gear ratio, in range: 1.0 to 20.0;
- Engine RPM, in range: 6000 to 25000 RPM. (Will be calculated automatically)

STEP7: Gov Gain setting, range: 50% to 300%;

Suggestion: 50% for Nitro engine; 150% for gasoline engine;

Governor STARTS to work in **all** of the following conditions:

- throttle stick position is higher than 20% from cut-throttle;
- When engine speed has been raised above 70% of set RPM;
- When engine speed sensor works correctly.

Governor STOPS working in **either one** of the following conditions:

- Throttle stick position lower than 10% from cut-throttle;
- Engine speed < 3000 RPM or sensor not working.

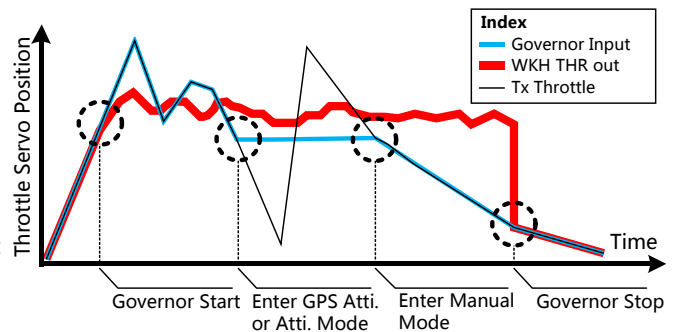

GPS Atti. and Atti. Modes takeover the throttle, pitch & cyclic positions at the point of switching from **Manual mode**. It is essentially how WKH knows to maintain throttle relative to rotor RPM, hence throttle hold or throttle cut switch will not cut the engine or motor. Unless, it is switched back to **Manual Mode**.

B8 R/C Transmitter Calibration



In Assistant Software, page-TX MONITOR:

TX MONITOR WIZARD STEP 2,7/8

Control Mode Switch

U

MANUAL

Fail-Safe

Att.

Fail-Safe

GPS Att.

Sticks Monitor

T

G

Command Sticks Calibration

P

R

E

A

STEP1

Calibration START



Totally 4 TX channels are required to be calibrate:

STEP1. Click **[START]** button, and move all of the sticks throughout their complete range several times.



STEP2. Click **[FINISH]** button when you finished above procedures.



- 1 You have to finish the throttle and pitch curve setting before calibration, here the end-point of transmitter sticks will be record.
- 2 If the throttle or pitch end-point of transmitter had been changed, please calibrate it again.

B9 System Check

Very important, check them carefully!



You have to run the system check using Assistant software—**System Check** for WKH system to work properly:

● Controller Output Check

- 1 Switch to **Non-Manual mode** first.
- 2 Click **[START]** button, WKH will drive the **swashplate** going up and down, representing collective movement during flight.
- 3 Click **[NEXT]** button, WKH will drive the **swashplate** going forward and back, representing elevator movement during flight.
- 4 Click **[NEXT]** button, WKH will drive the **swashplate** going left and right, representing aileron movement during flight.



- 5 Click **[NEXT]** button, WKH will drive the **rudder**, representing rotating C.C.W. and then C.W.



- 6 Click **[END]** button or switch to **Manual mode**, Controller Output Check will be finished.



If the swashplate or rudder moves in opposite sequence, you should click reverse button for correction.

If the swashplate or rudder still doesn't move as you expected, it may be caused by a wrong connection between WKH main controller and R/C Receiver, please also check the swashplate setting and Tail-Gyro setting.

● IMU Feedback Check

- 1 Switch to **Atti. or GPS Atti.Mode** first.
- 2 Click **[CHECK]** button.
- 3 Tilt the tail boom of the helicopter, the swashplate should respond to the opposite direction.
- 4 Tilt the helicopter body on its roll direction, the swashplate should also respond to the opposite direction.
- 5 Switch to **Manual mode** and finish the IMU Feedback Check.



- 1 If your helicopter was not responding as described above, you may be placing your IMU in a wrong orientation, or you've selected a wrong orientation for your IMU in Assistant Software. Please check sensor mounting again.
- 2 If the swash is not level (This is not critical), this can be caused by:
 - IMU is not level to AIR frame;
 - AIR frame and landing skids are not level to ground.

Battery Performance Test



- 1 Switch to **Non-Manual mode** first.
- 2 Make sure that your battery has at least 80% capacity left from being fully charged.

- 1 Click **[START]** button, WKH will force all the servos you connected and LEDs working at maximum payload, which will behave as shaking swashplate and rudder. This will continue for 20 seconds and then stop automatically, you can force it stop by clicking **[STOP]** button, or switch to **Manual mode**.

- 2 Assistant Software will inform you the test result (LED will also blink in yellow if you have it and failed condition was matched):

Failed, it means voltage drop below 3.5v, the battery or BEC were not able to provide necessary power, please change it.

Test passed.

B10 Autopilot



In Assistant Software, page-Autopilot:

AUTOPILOT

Basic Parameters

	Front/Back	Left/Right	Vertical
Gain	0%	0%	0%
Agility	0%		
Stick Delay	0%		

Advance Parameters

	Front/Back	Left/Right	Vertical
Velocity Tracking			0.0%
I	0%	0%	0%

No these two items in WKH Lite

DEFAULT



Transmitter related channels

Input	Operation	Description
U	Switch	Control Mode Switch
G	Switch	Quickly slide it from rate mode to head-locking mode for 3 times, all the command sticks center position would be reset, see page 15 for tail gyro working mode setting.
P	Stick	Up/Down command from Tx
E	Stick	Front/Back command from Tx
A	Stick	Left/Right command from Tx
R	Stick	Rudder command from Tx

Suggested Parameters

	ALIGN600 Nitro			ALIGN 600Elec.			LOGO 700			Maxi Joker 3DD			JR GSR260		
	F/B	L/R	V	F/B	L/R	V	F/B	L/R	V	F/B	L/R	V	F/B	L/R	V
Gain	100	100	100	130	110	80	150	151	100	160	160	110	155	165	130
Agility		100			150			130			100			175	
Stick Delay		100			110			135			185			166	
Velocity Tracking			100			113			100			100			100
I	100	100	100	114	115	116	100	100	100	100	100	100	100	100	100

Base Parameters

● Gain

Range: Front/back & Left/Right 40% ~ 400%; Vertical 50%~250%

If too large, you will find the helicopter oscillating in the corresponding direction (About 5~10 times per seconds). If too small, the helicopter will likely to be hard to control.

(**Lite** WKH Lite user can skip this section) In **GPS Atti**.

Mode, if helicopter drifting on front/back or left/right direction for 2~5 meters, then increase 10% on the corresponding direction it drifts to until the helicopter getting oscillation. If helicopter vibrate on its vertical direction, then reduce vertical parameter by 10% until it get stable. If altitude drop and drift happens during sharp braking, then increase I.D.R-Vertical in advance parameters.

● Agility *Range: 50% ~ 200%*

It determines the start-up speed from command stick, the bigger the value the faster the reaction. Increase it for sharper and quicker leveling action after command stick released. The control feeling will be stiffness and rigid if the value is too high; and sluggish leveling action and slow braking if too small.

● Stick Delay *Range: 50% ~ 200%*

It determines the overall stick reaction speed, for example: You push your roll stick to the maximum position your helicopter will tilt from leveling to 45 degrees, the smaller the number the quicker the transition.

Advance Parameters

The default values are suitable for most of the condition. DJI specialized guidance is needed if change is necessary.

● Velocity Tracking: *Range: Vertical 20.0% ~ 150.0%*

● I: *Range: Front/Back & Left/Right & Vertical 0% ~ 500%*

Lite WKH Lite does not have I of Front/Back & Left/Right.

Flight

C1 Digital Compass Calibration

Lite WKH Lite customers can skip this step.

Why calibrate the compass?

Ferromagnetic substances placed on helicopter or around its working environment will affect the reading of earth magnetic for digital compass, it also reduces the accuracy of the helicopter control, or even reads incorrect heading. Calibration will eliminate such influences, and ensure WKH system performs well in a non-ideal magnetic environment.

When to do it?

- 1 The first time you install WKH on your helicopter.
- 2 When the helicopter mechanical setup is changed:
 - a) If the GPS/Compass module is re-positioned.
 - b) If electronic devices are added/removed/re-positioned (Main Controller, servos, batteries, etc).
 - c) When the mechanical structure of the helicopter is changed.
- 3 If the flight direction appears to be shifting (meaning the helicopter doesn't "fly straight").
- 4 The LED indicator often indicates abnormality blinking when the helicopter yaws. (It is normal for this to happen only occasionally.)

Where to do it?

Do the calibration in an open area, away from parked cars, metal railings, and any metal around. Sometimes a bunch of keys in your pocket might affect calibration.

- 1 Don't calibrate your compass where there is strong magnetic interference, such as magnetite, car park, and steel reinforcement under the ground.
- 2 DO NOT carry ferromagnetic materials with you during calibration, such as keys or cell phones.
- 3 You don't need to rotate your helicopter on a precise horizontal or vertical surface, but keep at least 45° difference between horizontal and vertical calibration.
- 4 WKH cannot be work in the polar circle.

Calibration procedure:



- STEP1:** Enter calibration mode: quickly slide the control mode switch from **Position-1** to **Position-3** for 10 times, and LED indicator will be constantly on in blue;
- STEP2:** Calibration in horizontal: rotate you helicopter along with the horizontal surface until the green light is on constantly, then go to the next step;
- STEP3:** Calibration in vertical: while green light is constantly on, hold your helicopter vertically and rotate it along with its vertical axis, keep rotating until the green light is off, meaning the calibration is finished.

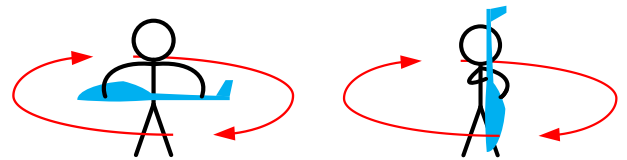

- STEP4:** After you finished the calibration, LED indicator will show whether the calibration was successful or not:
- If white light turns on for 3 seconds, calibration succeeds, calibration mode will **auto exit**;
 - If red light keeps blinking quickly, the calibration has failed. Slide the control mode switch one time to cancel current calibration, and then re-start from step 1 for re-calibration.



If you keep having calibration failure, it might suggest that there is very strong magnetic interference around the GPS & Compass module, please avoid flying in this area.

C2 MANUAL MODE Test Flight



- 1 When the system is powered on, DO NOT move your helicopter or sticks on transmitter until the system initialization is finished (about 5 seconds).
- 2 Don't switch to **Atti. Mode** or **GPS Atti. Mode** during **Manual Mode Test Flight**. Go through this section first, and read about how to do **Autopilot Test Flight** on **Page 23**.



- 1 Fly the helicopter. Trim transmitter such that the helicopter hovers stably.
- 2 You have to adjust the following parameters to achieve the best performance of your helicopter.
 - **Flybarless** parameters, if you've enabled Flybarless, see **Page 13** for details.
 - **Tail Gyro** sense, see **Page 15** for details.
 - **Engine speed**, if you are using Gasoline / Nitro engine, see **Page 16** for details.
- 3 Adjust Pitch curve on transmitter, so that the helicopter hovers at about mid-stick.
- 4 Set correct fail safe output on all channels of your R/C Transmitter/Receiver.
- 5 Verify Fail safe output of your transmitter on status bar in Assistant Software. **IMPORTANT!** The Fail-Safe (Auto Hovering or Level) has not been activated yet, goes through this section first and read about how to activate it on **Page 22**.



STEP1: Check all the connection and wiring connected firmly, and make sure they are in good condition;

STEP2: Make sure your batteries are fully charged for your transmitter, WKH and all the devices on your helicopter;

STEP3: Turn on the transmitter first;

STEP4: Power on WKH and all the rest of electric devices on helicopter, except brushless motor controller;

STEP5: Check the LED indicator, if red LED blinks quickly & continually, then system start-up has failed; you have to place your helicopter horizontally and power on again. See Appendix for details about LED indicator;

STEP6: Slide the control mode switch on your transmitter to make sure it is working properly. Check LED indicator to specify the current working mode. See Appendix for details about LED indicator;

STEP7: Others system failure and error will also be displayed by LED indicator, See Appendix for details;

STEP8: If everything checked, and without any problems, switch the system to **Manual Mode**, move all the sticks on your transmitter to check whether the helicopter is correctly responding to your commands;

STEP9: Start the engine or power on the brushless motor controller;

STEP10: Take-off and fly your helicopter in **Manual Mode**, before switching to other modes.

C3 Fail-Safe

WKH can detect the fail safe output from your receiver, if you have pre-set fail safe output correctly. Once your helicopter lost signal from the transmitter, Fail-Safe function will control the helicopter automatically and save it in most of the conditions.

- 1 The Fail-Safe (Auto Hover or Level) will not be activated, until you've correctly Pre-set Transmitter Command Stick Center Position.
- 2 The Fail-Safe functions will not be working correctly if you have not finished the **Auto Mode Test Flight**. Please see **Autopilot Test Flight** on **Page 23** for details.
- 3 You must perform the following setting under **Manual Mode**.
- 4 If GPS signal reception is bad or you are using **WKH Lite**, auto level function will be triggered, but no position holding.
- 5 If you have already setup Fail-Safe successfully, then main rotor will start if you switch off Tx when your helicopter is powered on.



In Assistant Software, page–Failed-Safe:

FAILED-SAFE

You have to do Tx Calibration before setting here!

STEP3

TX Center Position

	current position	Confirmed
T	<input type="text"/>	0
A	<input type="text"/>	0
E	<input type="text"/>	0
R	<input type="text"/>	0
P	<input type="text"/>	0

Please set this carefully, otherwise failed-safe function would not work as we designed.

I have confirmed the TX center position

STEP4

STEP1: Please configure your autopilot to the best condition, make sure the helicopter can flight well under **GPS Atti. Mode**;

STEP2: Switch you WKH into **Manual Mode**;

STEP3: Please record your command stick positions which are the same as the moment you switched from **Manual Mode** (if you changed throttle curve before switching, use that curve for this setting). You will be asked to configure your transmitter, and let your helicopter able to hover with transmitter command stick roughly (Not to be exact) on their center position. You can read the **[current stick position]** which shown as number -1000 to +1000 in real time, click button, save them into **[Confirmed]**group as Tx center position.

You will be noticed by symbol instead of button, which means your throttle working range has not

been correctly set or your throttle position is holding on throttle-cut (STOP) position. Please check your throttle-cut switch and throttle working range setting in Assistant Software page–Engine. See page16 for details.

STEP4: Must check the confirm box that the Tx center position is correct, otherwise failed-safe will be disabled.

Fail-Safe functions are designed for **GPS Atti. Mode and Atti. Mode**. Once the helicopter is in the available transmitter signal range, switch to **Manual Mode** then you can re-gain the control right for WKH system. **Lite** WKH Lite user should mind that, once the helicopter is in the available transmitter signal range, you re-gain the control right for WKH Lite system whichever control mode you are in!

C4 Autopilot Test Flight

■ WKH Test Flight (Lite WKH Lite user should skip this section to *WKH Lite Test Flight* section on next page)

 When system is powered on, you must not move your helicopter or sticks on transmitter until the system initialization is finished (about 5 second).



Please read this section before you switched to *Atti. Mode* and *GPS Atti. Mode*

- 1 Make sure the GPS signal is good, without red LED blinking.
- 2 Please avoid using WKH system in the following areas, where will GPS signal is most likely blocked:
 - Urban area with crowded buildings
 - Tunnels
 - Under bridges
- 3 Make sure the attitude of helicopter is in good condition, without white LED blinking.
- 4 Other system failures and errors will also be displayed by LED indicator (see Appendix for details) or in assistant software.
- 5 If WKH has already acquired the GPS signal, you cannot unplug GPS module directly without reboot and fly in GPS Atti Mode.

→ **Semi-Auto take-off**

Please setup **B7 Engine Governor** and all center positions correctly before you use this function. On **STEP11**, the system can perform **Semi-Auto take-off** feature rather than manual take-off. Please follow the operation procedures strictly:

- 1 Put the throttle stick on the lowest position;
- 2 Switch to **GPS Atti.** or **Atti. Mode** and wait **until the speed of main rotor is stable** ;
- 3 Requiring only pushing the throttle (collective pitch) stick gently to take-off the helicopter, autopilot system will be in charge of the cyclic pitch/roll stabilization.

→ **Semi-Auto Landing**

In **GPS Atti.** or **Atti. Mode**, with throttle (collective pitch) stick operation only, descend the helicopter and hold throttle stick on lowest position until the engine or electric motor is cutoff automatically. This throttle idle or shut-down in Auto mode when collective is lowest stick position only applies having this option.



- 1 With this option, MC will perform in **GPS Atti.** Or **Atti. Mode** for both takeoff and landing.
- 2 Make sure use this function only when the GPS signal is sufficient and at open area!
- 3 When you are using semi auto take off, switch into autopilot modes and move throttle stick, main rotor will start!

STEP1: Check all connections and wirings, and make sure they are in good condition;

STEP2: Make sure your batteries are fully charged for your transmitter, WKH and all the devices on your helicopter;

STEP3: Turn on the transmitter first;

STEP4: Power on WKH and all the rest of electric device on helicopter, except brushless motor controller;

STEP5: Check the LED indicator. If red LED sparks quickly, the system start-up has failed. You will need to place your helicopter horizontally and power on again. See Appendix for details about LED indicator;

STEP6: You may find red LED blinking, indicating that WKH is getting GPS satellite signal, please wait until red LED is off, meaning WKH have found more than 7 GPS satellites, and that it can work in its best condition. See Appendix for details about LED indicator;

STEP7: Slide the control mode switch on your transmitter to make sure it is working properly. Check it with LED indicator to specify the current working mode for WKH. See Appendix for details about LED indicator;

STEP8: Switch the system to **GPS ATTi. Mode**, if the swashplate is not horizontal, please go back to 3rd step, and power cycle the system;

STEP9: Switch the system to **Manual Mode**, move all the sticks on your transmitter to check whether the helicopter is correctly responding to your commands;

STEP10: Start the engine or power on the brushless motor controller;

STEP11: Take-off and fly your helicopter in **Manual Mode**;

STEP12: Hover your helicopter, and switch to **GPS ATTi. Mode**.



Do NOT move any stick when switching!

■ WKH **Lite** Test Flight

 When system is powered on, you must not move your helicopter or sticks on transmitter until the system initialization is finished (about 5 second).

 **Please read this section before you switched to *Atti. Mode***

- 1 Put helicopter on the plane ground.
- 2 System failures and errors will also be displayed by LED indicator (see Appendix for details) or in assistant software.

➔ **Semi-Auto take-off**

Please setup **B7 Engine Governor** and all center positions correctly before you use this function. On **STEP10**, the system can perform **Semi-Auto take-off** feature rather than manual take-off. Please follow the operation procedures strictly:

- 1 Put the throttle stick on the lowest position;
- 2 Switch to **Atti. Mode** and wait **until the speed of main rotor is stable** ;
- 3 Requiring only pushing the throttle (collective pitch) stick gently to take-off the helicopter, autopilot system will be in charge of the cyclic pitch/roll stabilization.

➔ **Semi-Auto Landing**

In **Atti. Mode**, with throttle (collective pitch) stick operation only, descend the helicopter and hold throttle stick on lowest position until the engine or electric motor is cutoff automatically. This throttle idle or shut-down in Auto mode when collective is lowest stick position only applies having this option.



- 1 With this option, MC will perform in **Atti. Mode** for both takeoff and landing.
- 2 When you are using semi auto take off, switch into autopilot modes and move throttle stick, main rotor will start!

STEP1: Check all connections and wirings, and make sure they are in good condition;

STEP2: Make sure your batteries are fully charged for your transmitter, WKH and all the devices on your helicopter;

STEP3: Turn on the transmitter first;

STEP4: Power on WKH and all the rest of electric device on helicopter, except brushless motor controller;

STEP5: Check the LED indicator. If red LED sparks quickly, the system start-up has failed. You will need to place your helicopter horizontally and power on again. See Appendix for details about LED indicator;

STEP6: Slide the control mode switch on your transmitter to make sure it is working properly. Check it with LED indicator to specify the current working mode for WKH. See Appendix for details about LED indicator;

STEP7: Switch the system to **Atti. Mode**, if the swashplate is not horizontal, please go back to 3rd step, and power cycle the system;

STEP8: Switch the system to **Manual Mode**, move all the sticks on your transmitter to check whether the helicopter is correctly responding to your commands;

STEP9: Start the engine or power on the brushless motor controller;

STEP10: Take-off and fly your helicopter in **Manual Mode**;

STEP11: Hover your helicopter, and switch to **Atti. Mode**.

 Do NOT move any stick when switching!

Maintains

Firmware Upgrade

Please strictly follow the operation procedure for firmware upgrade, otherwise WKH might not work properly:

1. Make sure your computer is connected to the Internet.
2. Please close all the other applications during the firmware upgrade, including Anti-virus software and firewall.
3. Make sure the power supply is securely connected. DO NOT un-plug the power supply until firmware upgrade has finished.
4. Connect main controller to PC with micro-USB cable, DO NOT break connection until firmware upgrade is finished.
5. Run Software and wait for connection.
6. Select **[TOOL]→[Firmware Upgrade]**.
7. DJI server will check your current firmware version, and get the latest firmware prepared for the unit.
8. If there is a firmware version more up-to-date than your current version, you will be able to click the upgrade button.
9. Wait until Assistant software reads "Finished".
10. Please power cycle the unit after at least 5 seconds.
11. Your unit is up-to-date now.



- After firmware upgrade, please re-configure WKH using Assistant software.
- If it is notified that the network or DJI server is busy, please try again later with above procedures.
- If firmware upgrade failed, WKH will enter **<waiting for firmware upgrade status>** automatically, please try again with the above procedures.

Note: You will be asked to fill out contact information/register as user prior to any upgrades

Product Info

You can check the WKH product version via **[ABOUT]→[Info]**.

- Software version
- Firmware version
- IMU version
- Hardware ID

[S/N] is a 32 digits authorization code for unit function activations. We had already filled in the authorization code for your unit after manufacture. You might be asking to fill in the new **[S/N]** in the future if you brought new function upgrades.

Fill-in the **[S/N]** and then click **[Write]** button.



If you filled in the invalid S/N over 30 times, your WKH will be locked and you have to contact our customer support.

Product Specifications

General	
Built-In Functions	<ul style="list-style-type: none"> ● Autopilot ● Tail Gyro ● Engine Governor for gas power ● Flybarless ● Auto Hover or Level Fail Safe ● Semi Auto Takeoff & Landing
Peripheral	
Supported Helicopter Types	<ul style="list-style-type: none"> ● Electric ● Internal combustion
Supported Swashplate Types	<ul style="list-style-type: none"> ● Normal ● Three Servo 120°/140°/90° ● Four Servo 90°
Supported Servo output	<ul style="list-style-type: none"> ● Rudder channel: Analog 50Hz ● Rudder channel: Digital 333-560Hz (760us-1520us) ● Other channels: Follow on your receiver output
Recommended Transmitter	PCM or 2.4GHz with minimum 7 channels and failed-safe function available on all channels.
Recommended Power Supply	DC 4.8~8.4V (Not to exceed MAX operating voltage of servo motor); >1500 mAh capacity, Discharge current more than 5C; 7.5A to 15A external BEC, servos dependent
Assistant Software System Requirement	Windows XP SP3 / 7
Electrical & Mechanical	
Power Consumption	MAX 5W (0.9A@5V, 0.7A@5.8V, 0.5A@7.4V, 0.4A@8V)
Operating Temperature	-5°C to +60°C
Total Weight	<= 150g (overall)
Dimensions	<ul style="list-style-type: none"> ● MC: 51.2mm x 38.0mm x 15.3mm ● IMU: 41.4mm x 31.1mm x 27.8mm ● GPS & Compass: 50mm (diameter) x 9mm ● LED Indicator: 25mm x 25mm x 7mm
Lite GPS/Compass is NOT in WKH Lite	
Flight Performance (can be effected by mechanical performance and payloads)	
Hovering Accuracy (GPS Mode)	<ul style="list-style-type: none"> ● Vertical: ± 0.5m ● Horizontal: ± 1m
Lite NOT with WKH Lite	
Maximum Wind Resistance	<8m/s (17.9mph / 28.8km/h)
Forward / Backward Speed	±72km/h (44.74mph)
Left / Right Speed	±56.7km/h (35.77mph)