

1/16 SCALE OFF-ROAD 4WD SERIES MANUAL

Addition Accessories 配送工具

Hex Wrench 六角扳钳

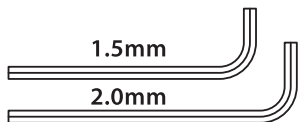

Small Cross Tool 小十字套筒

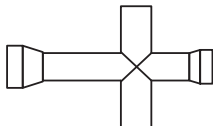

Tools Recommended 推荐工具

Hex screwdrivers
内六角螺丝刀

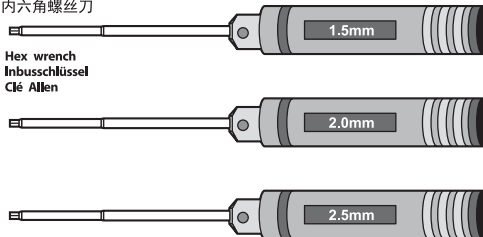

Hex wrench
Inbusschlüssel
Clé Allen

±Screwdriver (large)
±Schraubenzieher (gross)
Tournevis ± (gros)

Modeling knife
Modellermesser
Couteau de modéliste
刮刀



Side cutter
Seitenschneider
Pinces coupantes
剪钳



Curved scissors
Schere
Ciseaux
剪刀

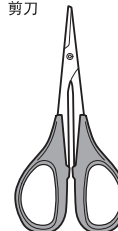

Long nose pliers
Flachzange
Pinces à becs longs
尖嘴钳

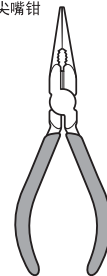

Model Glue
模型胶水

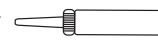

Chassis System Assembly 底盘装配

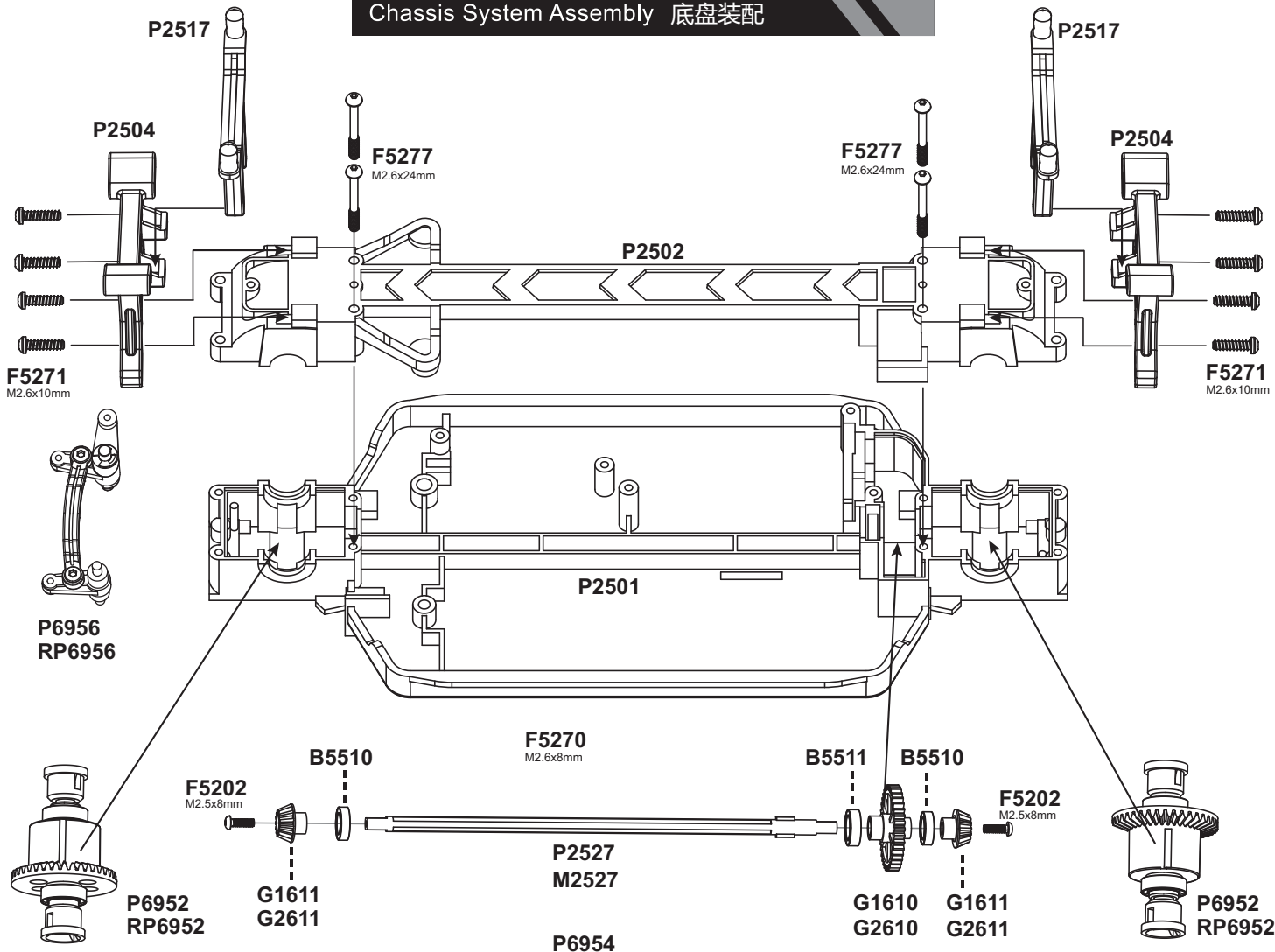

Front /Rear Differential Gear Box Assembly 差速器总成

P6951
RP6951

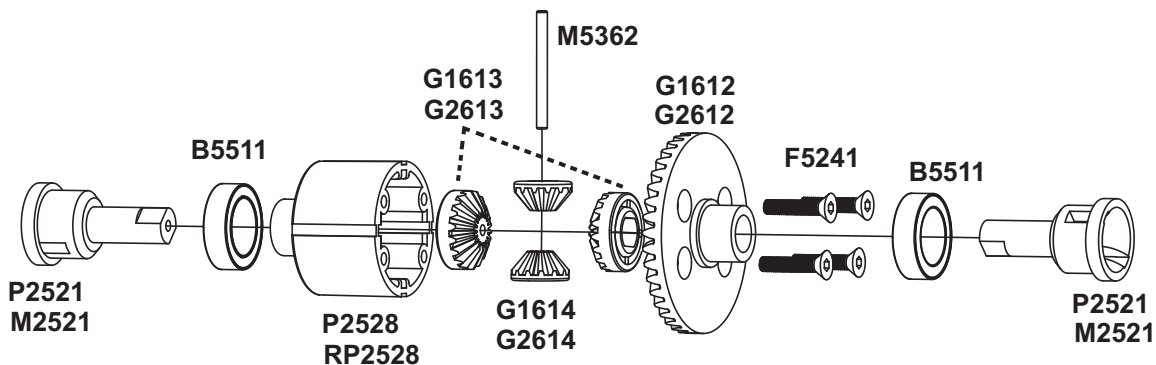

Servo Saver/Steering Assembly 转向缓冲总成

Steering Hubs Assembly 前轮座总成

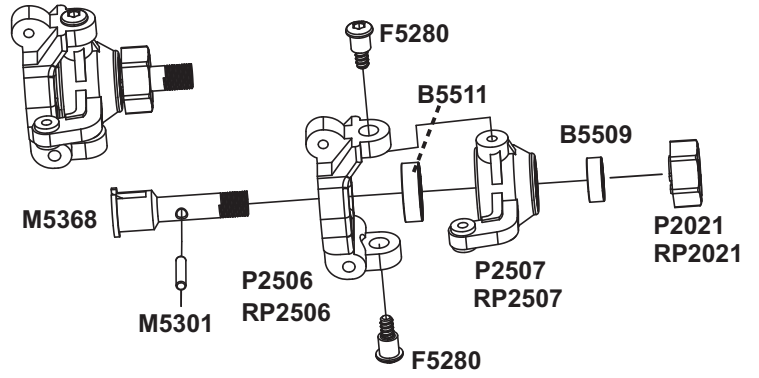
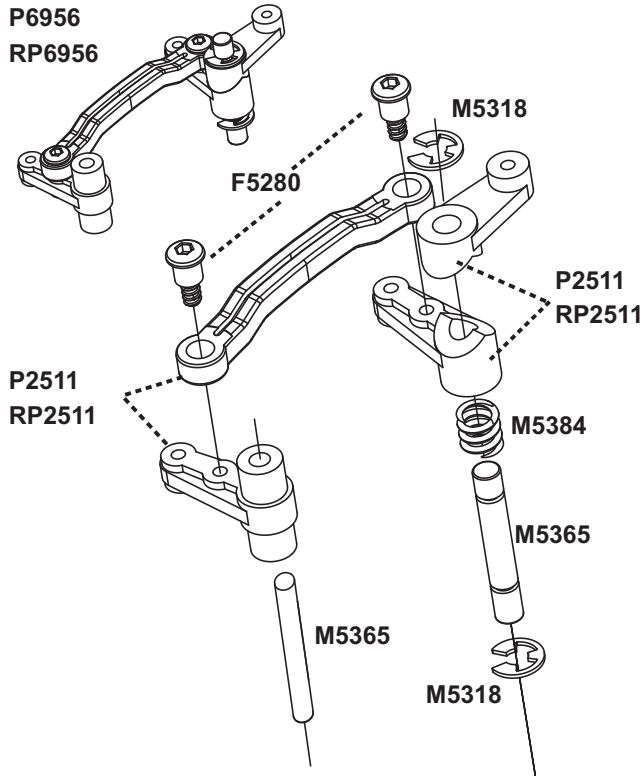

P2512 Steering Rod ends 转向拉杆

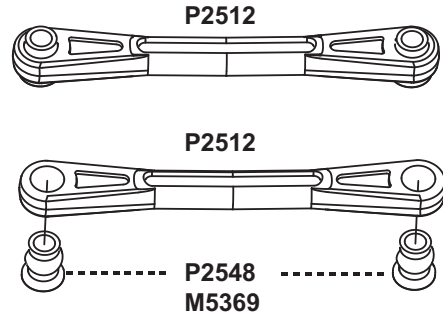

Shock Absorber

Carriers stub axle rear Assembly 后轮座总成

P2529 Linkage steering 伺服器拉杆

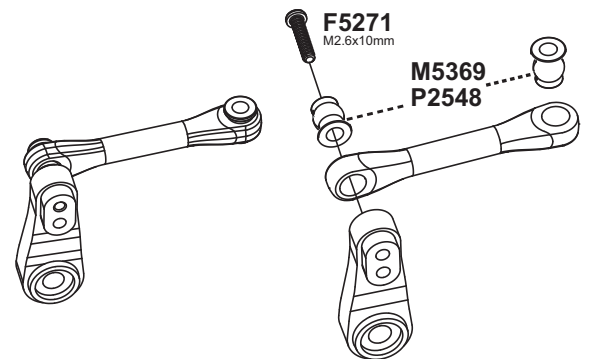
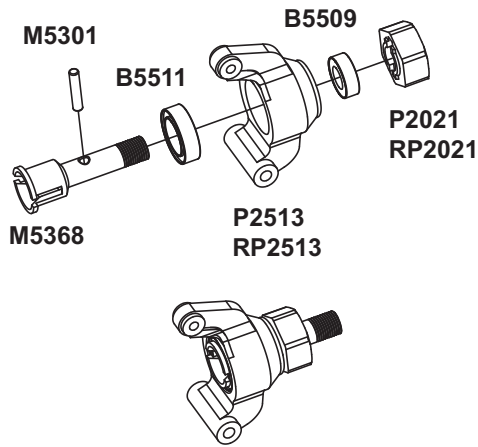
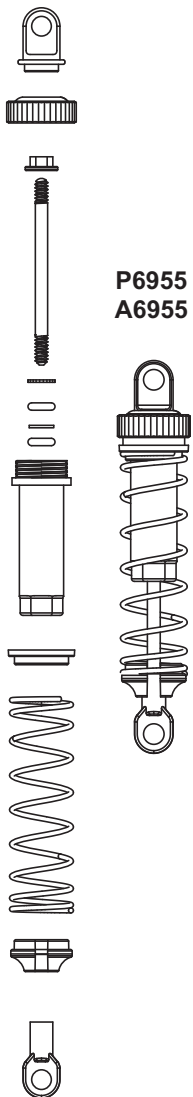

Tires Assembly 轮胎

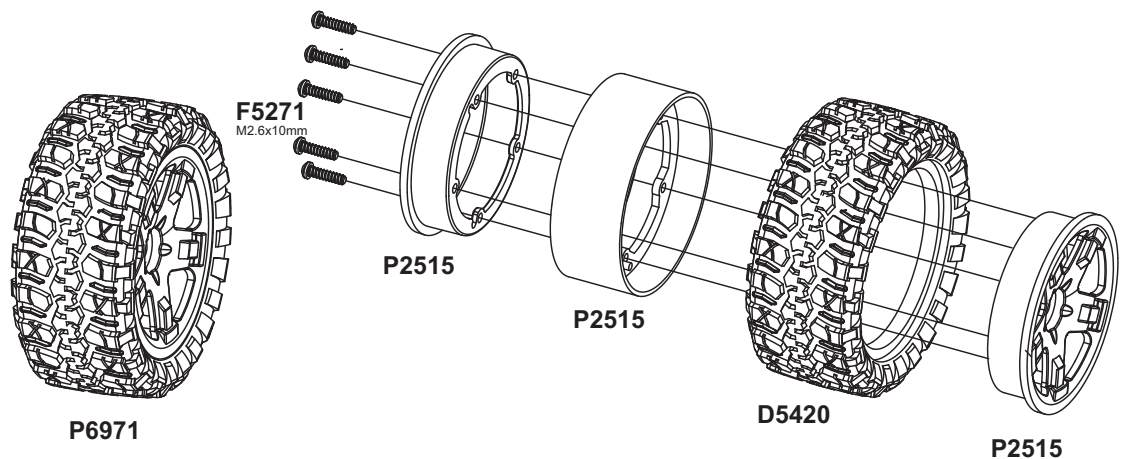

P2525 Bumper front 前保险架

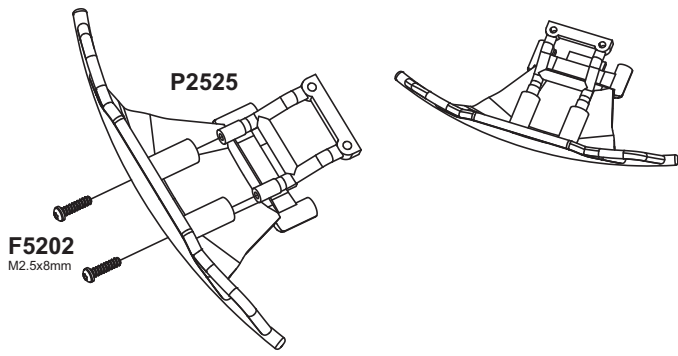

P2526 Bumper rear 后保险架

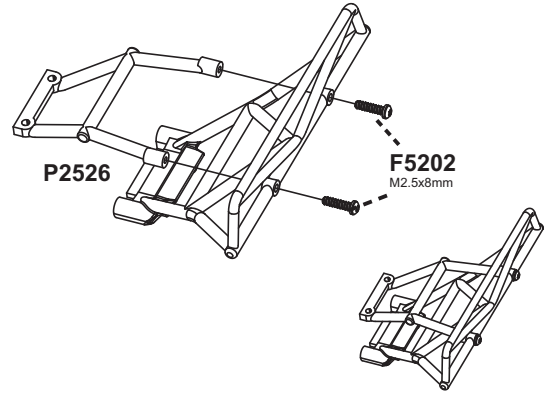

Short Course Truck Chassis System Assembly View 底盘系统装配图

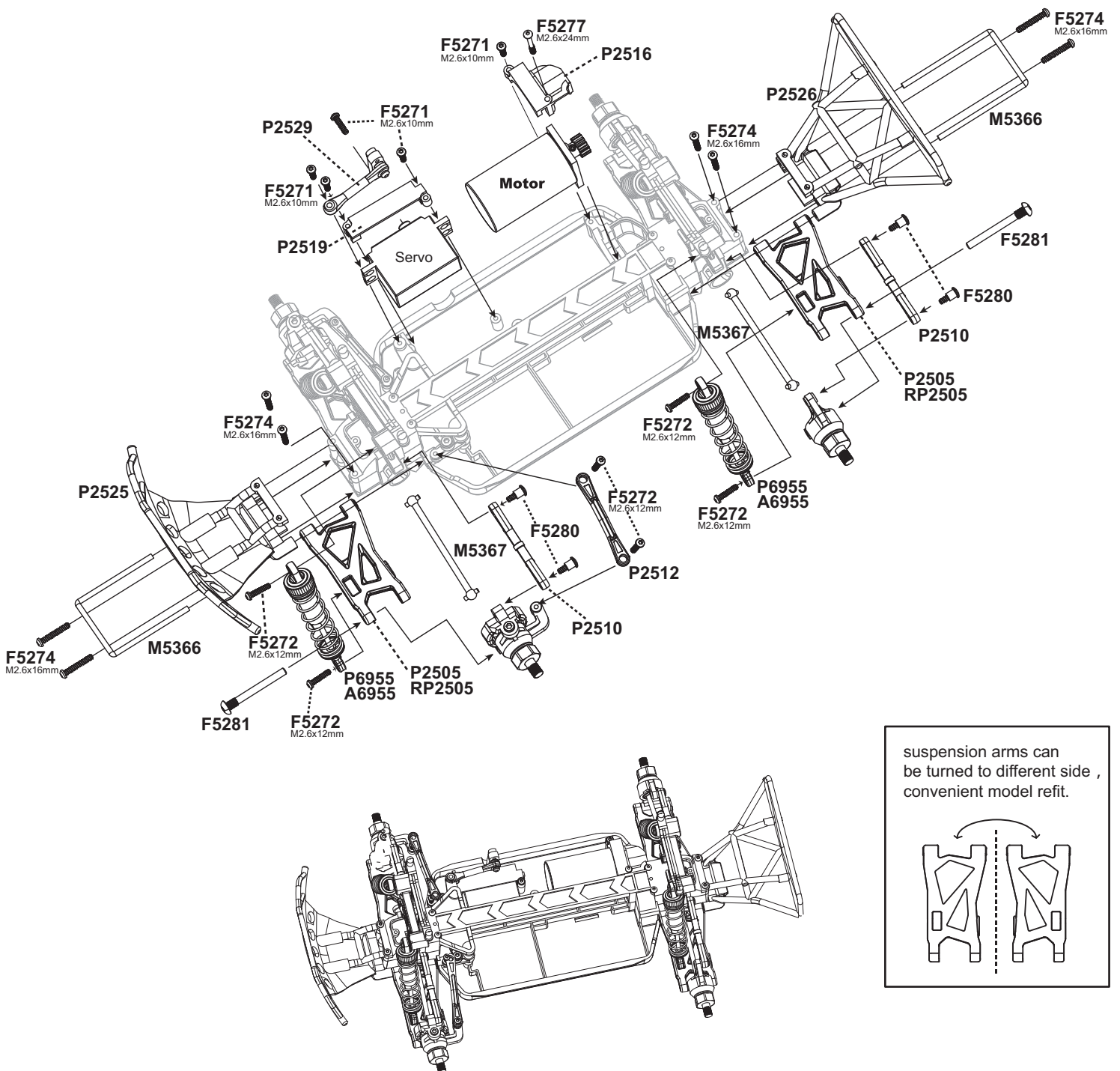

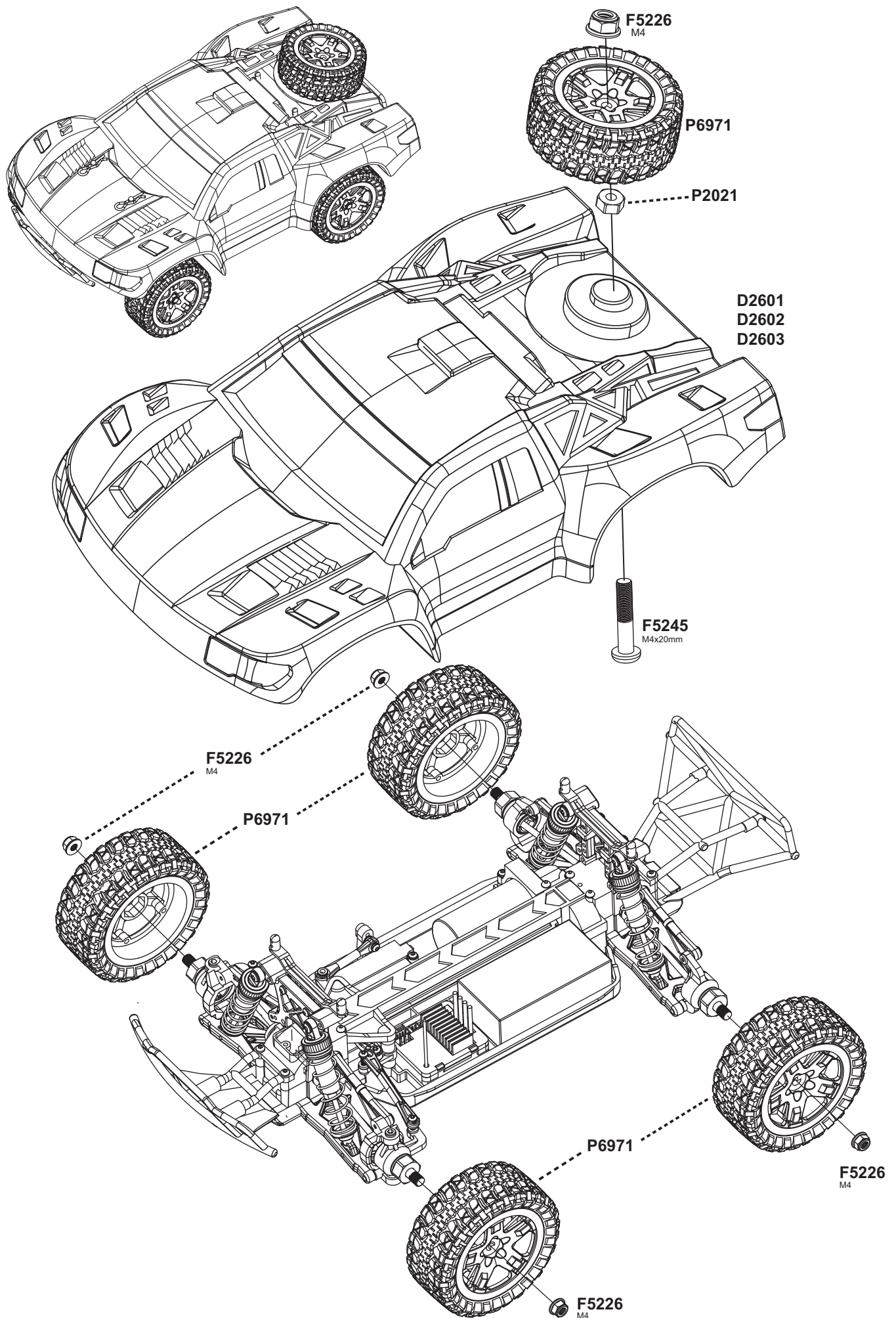

Motor pinion gear 马达齿轮 T 数安装图

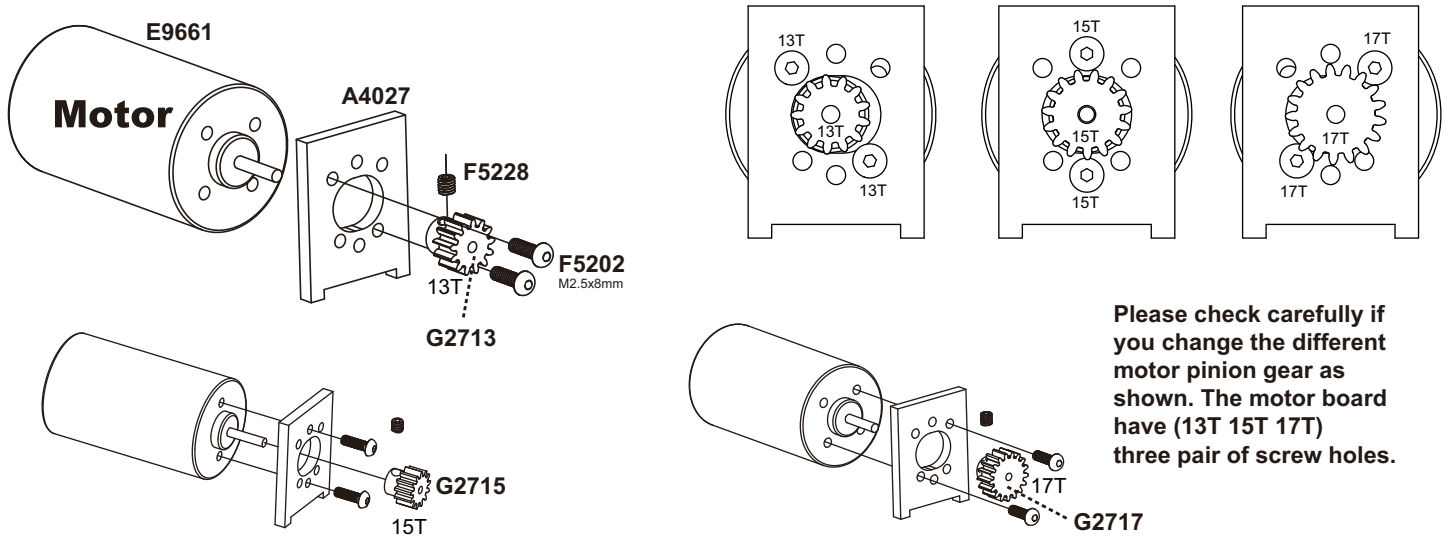

Monster Truck Chassis System Assembly View 底盘系统装配图

suspension arms can be turned to different side , convenient model refit.

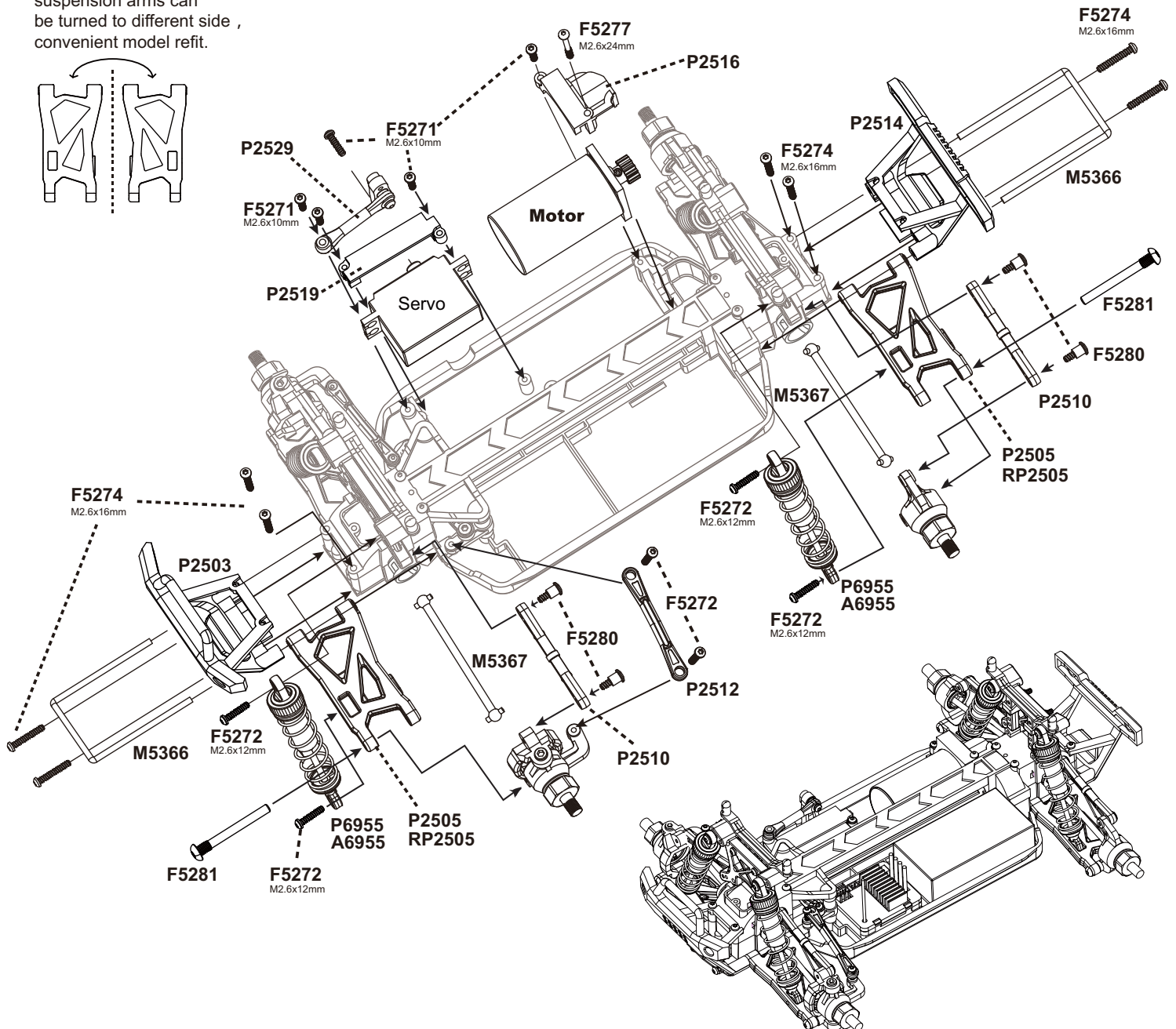

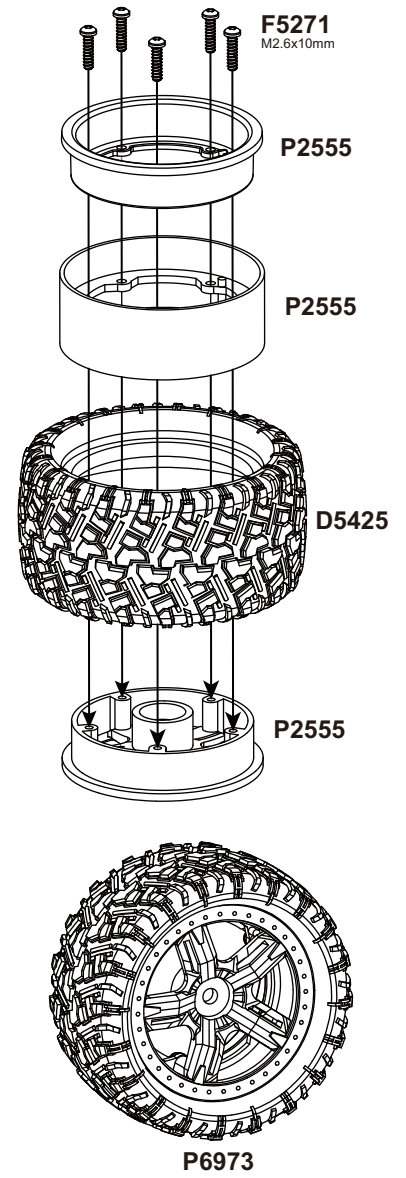
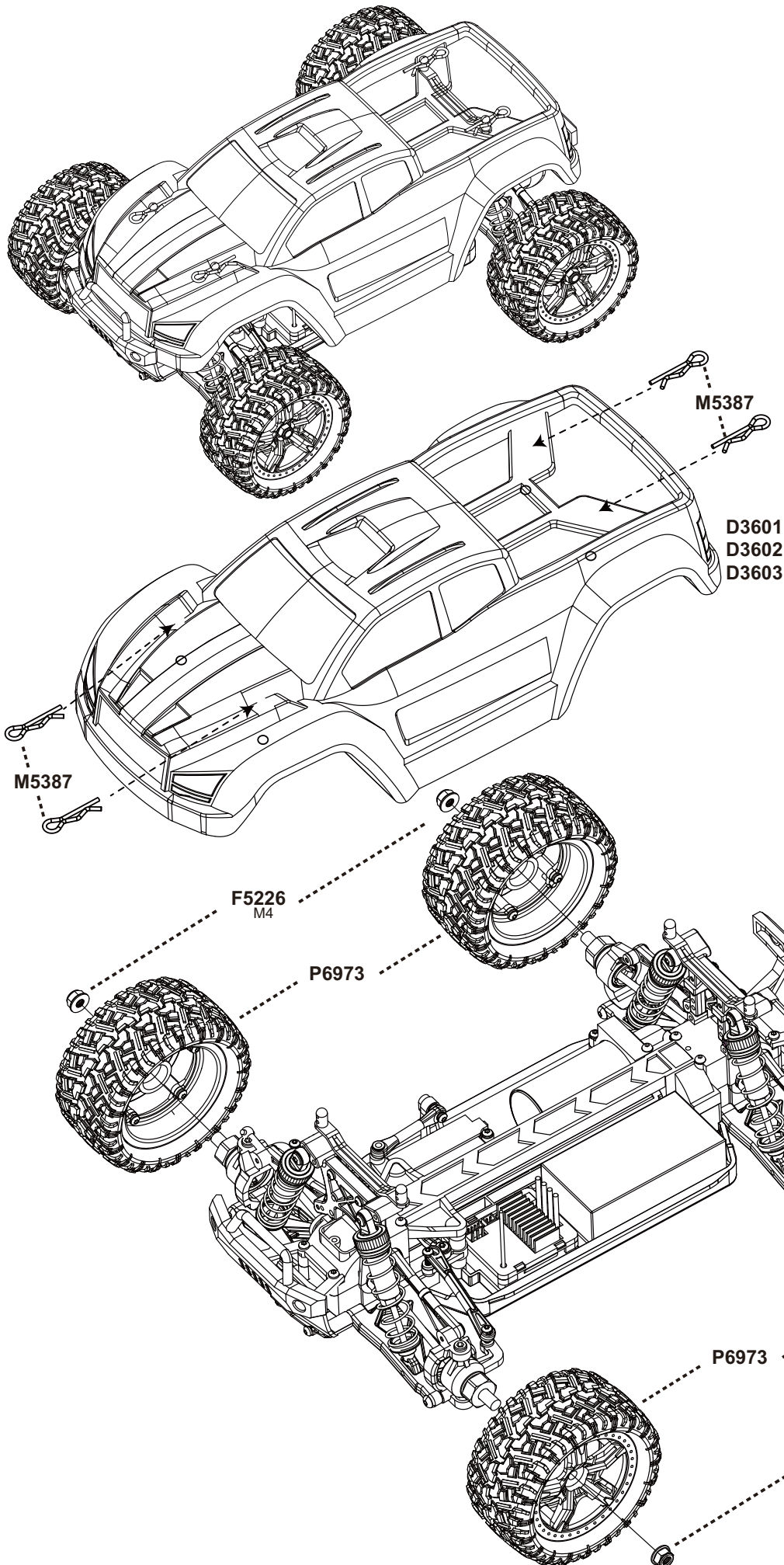

Electronic diagram of system installation 电子系统安装图

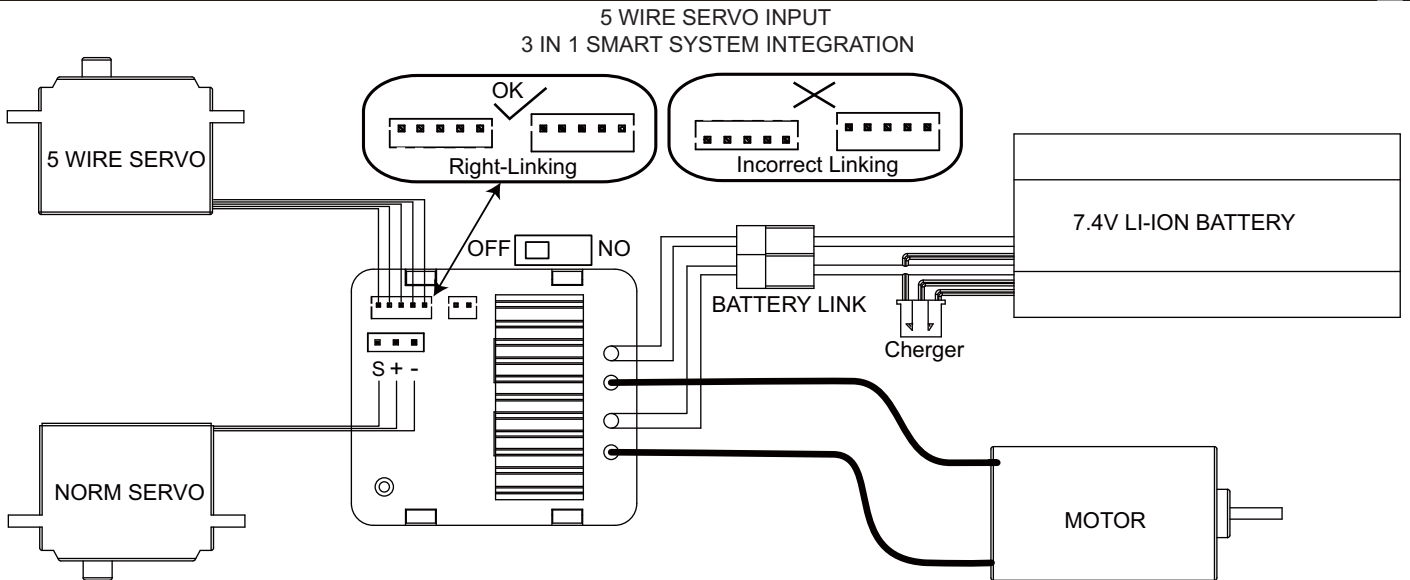

Buggy Chassis System Assembly View 底盘系统装配图

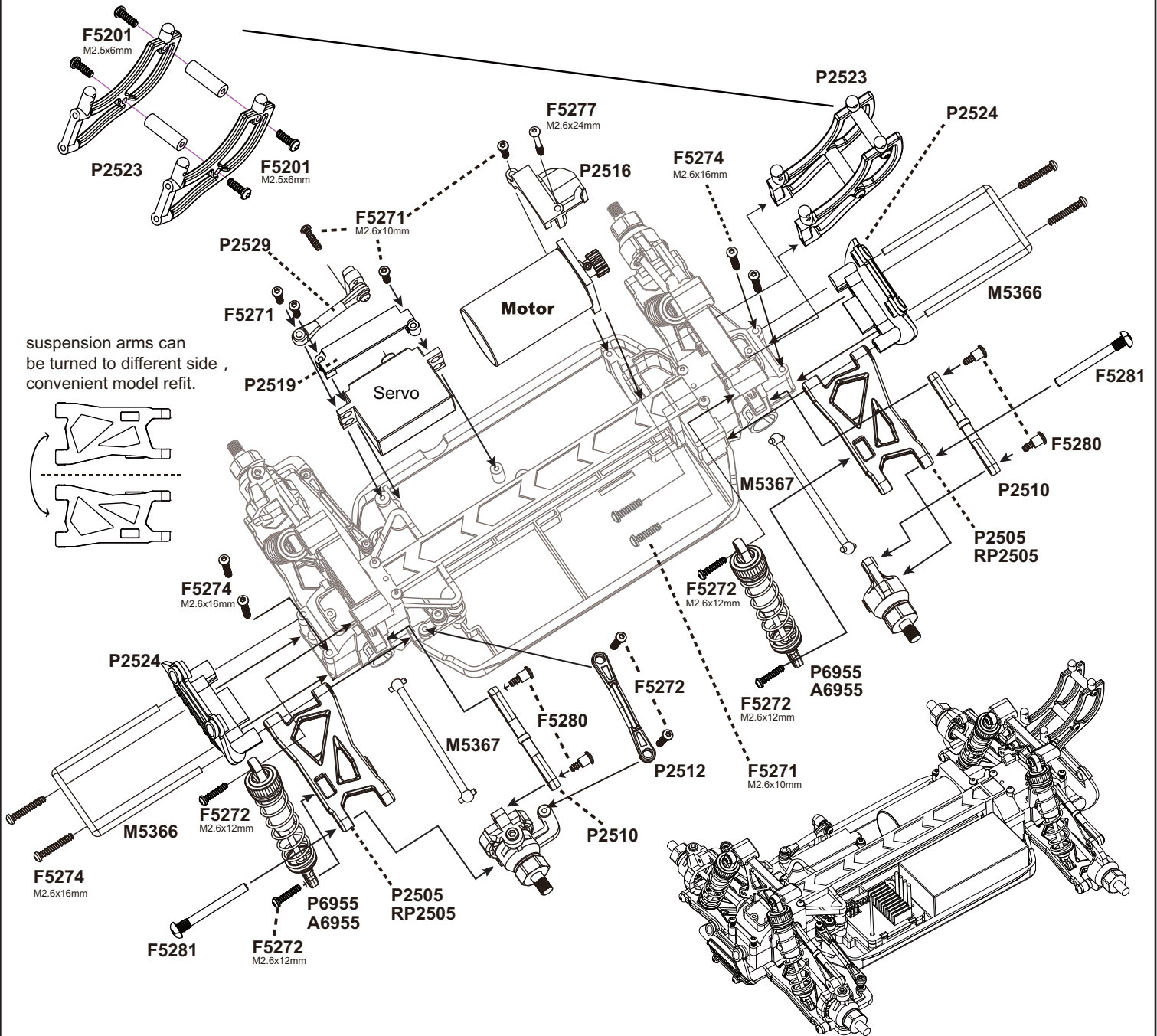

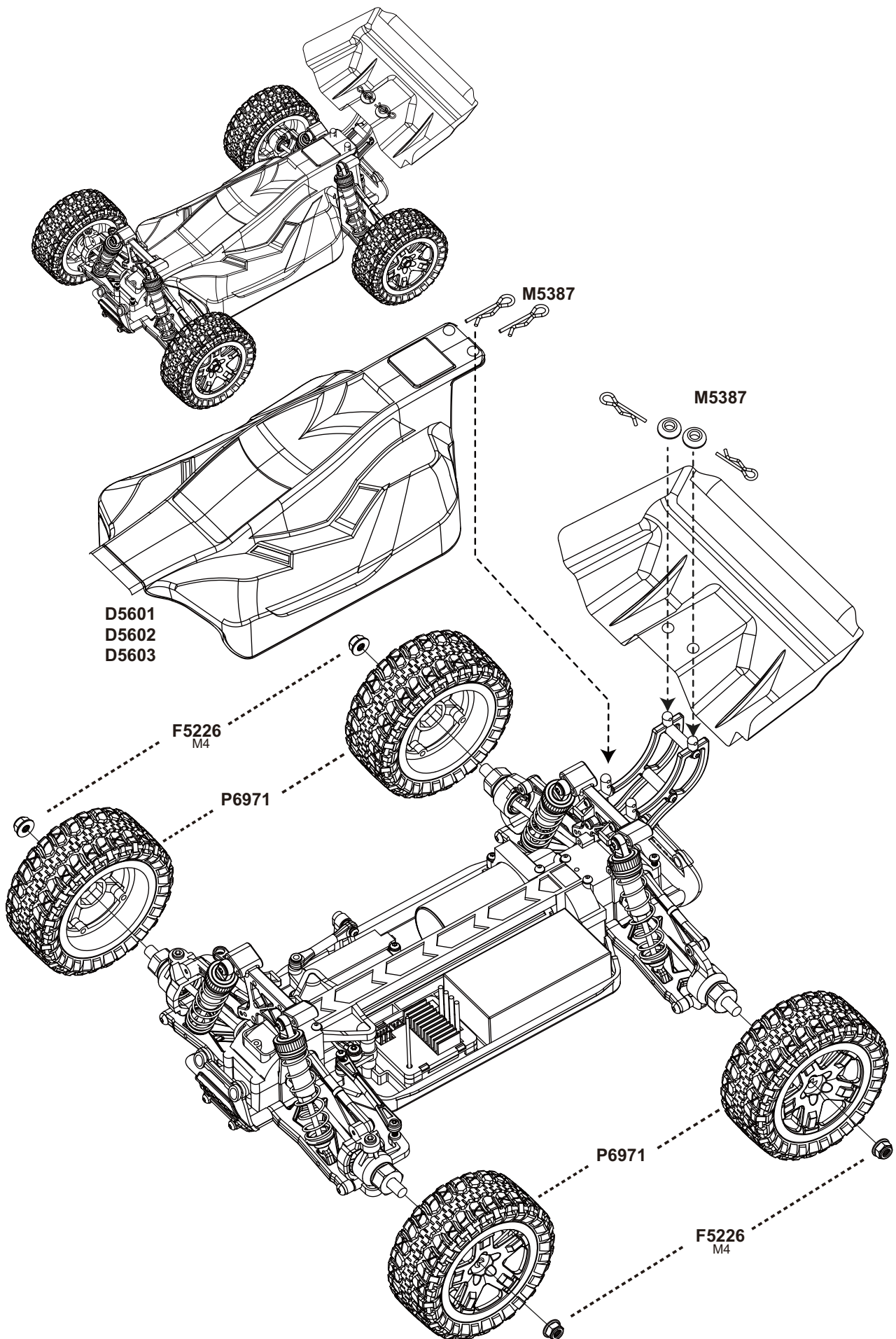

Caution: due to technique updates constantly, pictures are for reference only, products are subject to availability.
由于技术不断更新, 配件、数据和图片有所不同, 以实物为准!